

5

P-N Junction and Zener Diode

5.1 : Introduction

Q.1 What is p-n junction ?

Ans. : The two types of extrinsic materials are p type and n type.

- The p type and n type materials are chemically combined with a special fabrication technique to form p-n junction.
- On p-side there are large number of holes while on n-side there are large number of free electrons.

5.2 : Drift and Diffusion Current

Q.2 Write the difference between drift current and diffusion current.

[JNTU : Part A, Dec.-14, Marks 2]

Ans. : When a voltage is applied to a semiconductor then free electrons move towards positive of battery. Such a movement of free electrons is called drifting and resulting current is called **drift current**.

- When an impurity is added to intrinsic material, it is called doping. If this doping is nonuniform then the charge carriers either electrons or holes also exist nonuniformly in the material. As these carriers are of similar type, they repel each other so that their distribution becomes uniform in the material. Due to movements of such carriers, the current flows, which is called **diffusion current**. The movement of carriers without any external voltage, due to their nonuniform distribution is called **diffusion**. This plays an important role in the working of the unbiased p-n junction.

5.3 : Theory of P-N Junction
(Formation of Depletion Region)

Q.3 Explain the formation of depletion region in an unbiased p-n junction. [JNTU : Part A, Aug.-06, May-09, 12, 13,16, Dec.-12, Marks 3]

Ans. : • In unbiased p-n junction, there are large number of holes on p-side and large number of free electrons on n-side.

- Due to diffusion, the majority holes on p-side start diffusing into n-side while the majority free electrons on n-side start diffusing on p-side.
- In n-region, the holes diffusing from p-side recombine with the free electrons on n-side and become immobile positive ions, just near the junction in n-region.
- In p-region, the free electrons diffusing from n-side recombine with the holes on p-side and become immobile negative ions, just near the junction in p-region.
- The large number of negative immobile ions form on p-side near the junction while large number of positive immobile ions form on n-side near the junction. Due to this, further diffusion of holes and free electrons stops due to repulsion.
- Thus there exists a wall near the junction with negative charge on p side and positive charge on n side. There are no charge carriers in this region. The region is depleted of the charge carriers. Hence this region is called **depletion region, depletion layer or space charge region**.

The depletion region is shown in the Fig. Q.3.1.

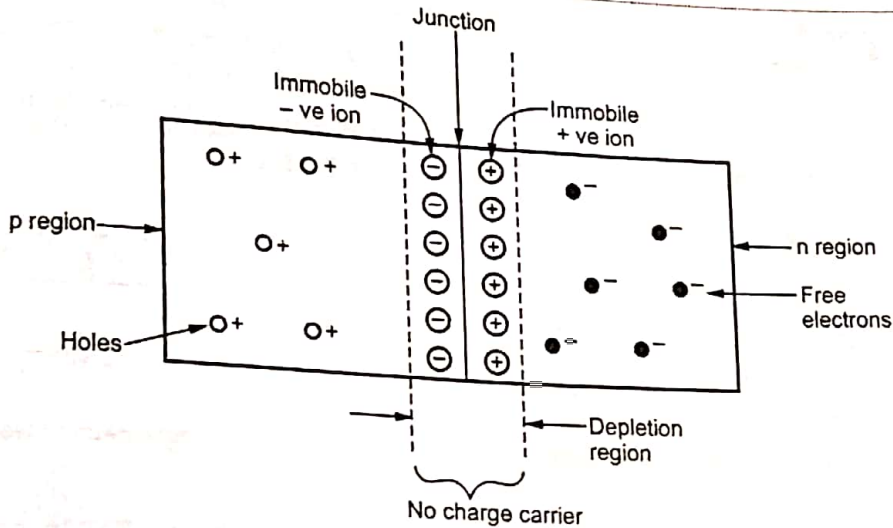

Fig. Q.3.1 Depletion region

Important Points to Remember

- In equilibrium condition, the depletion region gets widened upto a point where no further electrons or holes can cross the junction. Thus it acts as a barrier.
- Due to the immobile positive and negative ions on the either sides of depletion region near the junction, there exists potential difference across the junction. This is called barrier potential, built-in potential, junction potential or cut-in potential of p-n junction. For silicon, it is about 0.7 V while for germanium it is about 0.3 V.

5.4 : P-N Junction Diode

Q.4 Explain p-n junction diode.

Ans. : • The p-n junction forms a popular semiconductor device called p-n junction diode.

- Its two terminals are called electrodes, one each from p region and n region.
- It can conduct current only in one direction.
- The p region is anode and n region is cathode.
- Its symbol is shown in the Fig. Q.4.1. The arrowhead in the symbol indicates the direction of the conventional current which can flow when an external voltage is applied in a specific manner across the diode.

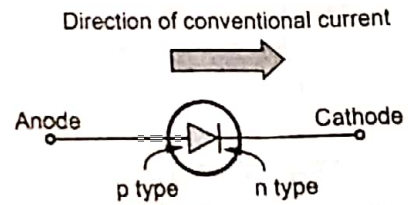

Fig. Q.4.1 Symbol of a diode

5.5 : Operation of Diode (Forward and Reverse Biasing)

Important Points to Remember

- Applying external voltage to p-n junction diode is called biasing.
- Depending upon the polarity of external d.c. voltage applied to diode, the biasing of diode is classified as,
 1. Forward biasing
 2. Reverse biasing

Q.5 Explain the operation of diode under forward and reverse biased conditions.

[JNTU : Part B, April-18, Marks 5]

Ans. : Forward Biasing :

- When an external d.c. voltage is connected in such a way that p region is connected to positive and n region to negative of the d.c. voltage then the biasing is called forward biasing. It is shown in the Fig. Q.5.1.

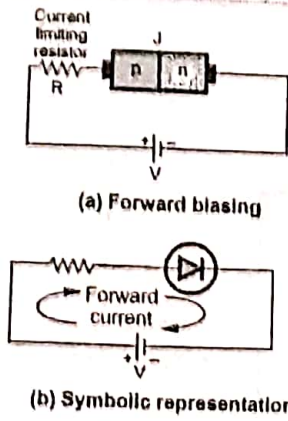

Fig. Q.5.1

- As long as applied voltage V is less than barrier potential there is no conduction.
- When applied voltage V is more than barrier potential, it overcomes the barrier potential and reduces the width of depletion region. This is because the negative of battery pushes the free electrons against the barrier from n to p region while positive of battery pushes holes against barrier from p to n region.
- As applied voltage is increased, at a particular value, the depletion region becomes very narrow and majority charge carriers can easily cross the junction.
- This large number of majority charge carriers constitute a current called **forward current**.
- The current in the p region is due to movement of holes so it is **hole current**. The current in the n region is due to movement of electrons so it is **electron current**. The holes in p region and electrons in n region are majority charge carriers. Hence the forward current is due to **majority charge carriers**.
- The forward current in a diode is shown in the Fig. Q.5.2.

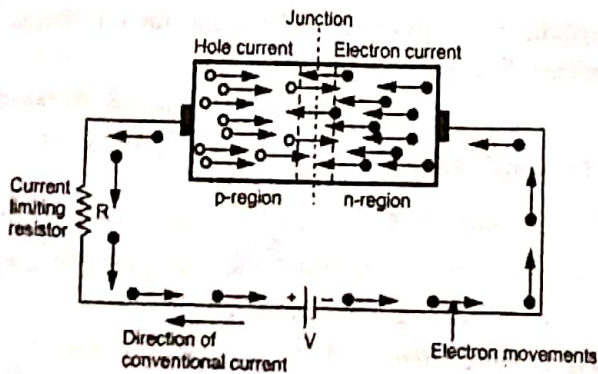

Fig. Q.5.2 Forward current in a diode

Reverse Biasing :

- When an external d.c. voltage is connected in such a way that p region is connected to negative and n region to positive terminal of the d.c. voltage then the biasing is called **reverse biasing**. It is shown in the Fig. Q.5.3.

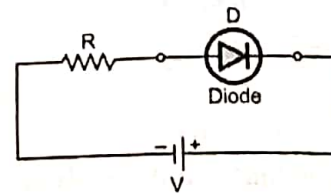
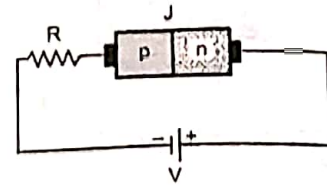
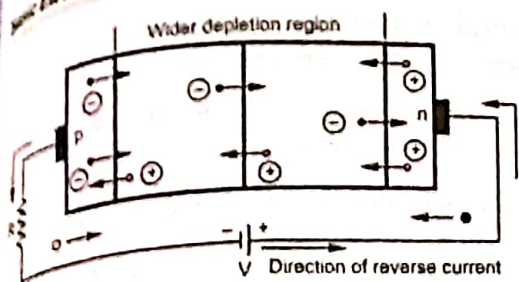
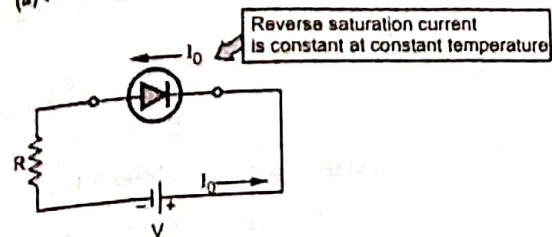

Fig. Q.5.3

- In reverse biasing, negative of battery attracts the holes in p region and positive of battery attracts the electrons in n region away from the junction.
- This widens the depletion region and barrier potential increases. No majority charge carrier can cross the junction.
- The resistance of the reverse biased diode is very high and the diode is said to be nonoperative in the reverse biased.
- However due to increased barrier potential, the free electrons on p side are dragged towards positive while holes on n side are dragged towards negative of the battery.
- This constitutes a current called **reverse current**. It flows due to **minority charge carriers** and hence its magnitude is very very small.
- For constant temperature, the reverse current is almost constant though applied reverse voltage is increased upto certain limit. Hence it is called **reverse saturation current** denoted as I_0 . This is shown in the Fig. Q.5.4.



(a) Flow of minority charge carriers



(b) Direction of reverse current

Fig. Q.5.4 Reverse biased diode

The reverse current I_0 is of the order of few microamperes for Ge and few nanoamperes for Si diodes.

5.6 : Volt-Ampere Characteristics of a Diode (V-I Characteristics)

Q.6 Draw and explain the V-I characteristics of p-n junction diode. [JNTU : Part B, Dec.-14, 16, 17, May-18, Aug.-18, Marks 5]

Ans. : • In forward biasing V_f is the voltage across the p-n junction and I_f is the forward current hence graph of I_f against V_f is called forward characteristics of p-n junction.

• The forward characteristics of a diode is shown in the Fig. Q.6.1.

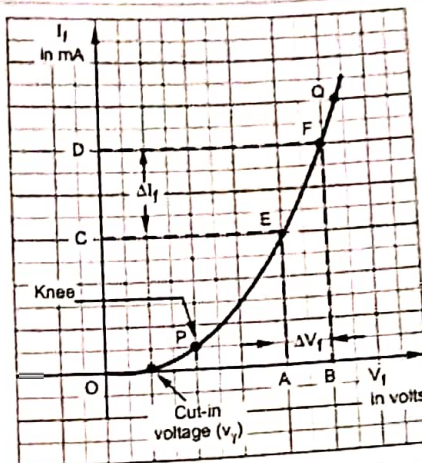

Fig. Q.6.1 Forward characteristics of a diode

- It is divided into two regions :
 1. Region O to P : As long as V_f is less than cut-in voltage (V_f), the current flowing is very small.
 2. Region P to Q and onwards : When V_f exceeds V_f i.e. cut-in voltage, the depletion region becomes very thin and current I_f increases suddenly. This increase in the current is exponential as shown in the Fig. Q.6.1 by the region P to Q.
- The point P, after which the forward current starts increasing exponentially is called knee of the curve and the corresponding voltage is called knee voltage.
- The reverse voltage across the diode is V_R and reverse current through the diode is I_R hence graph of I_R against V_R is called reverse V-I characteristics of p-n junction.
- As the reverse voltage is increased, reverse current increases initially but after a small voltage becomes constant equal to reverse saturation current I_0 . This point is shown as P, in the Fig. Q.6.2.

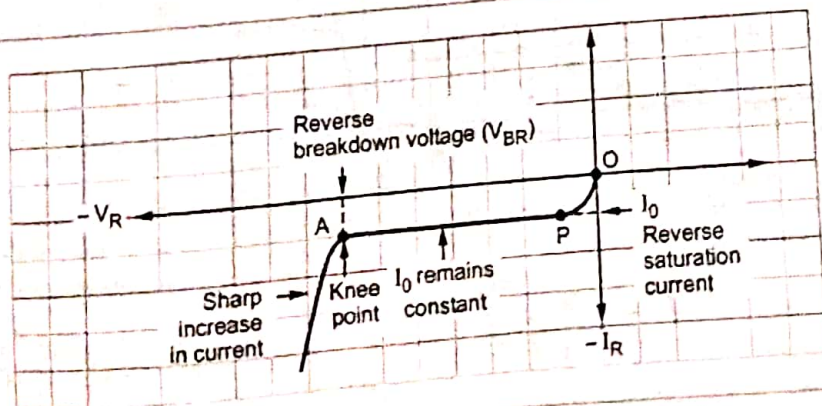

Fig. Q.6.2 Reverse characteristics of p-n junction diode

- After this, though reverse voltage is increased, the reverse current remains constant till point A where diode breakdown occurs.
- The point A is called knee point and the corresponding voltage is called reverse breakdown voltage of diode.
- The complete V-I characteristics of p-n junction diode is the combination of its forward as well as reverse characteristics. This is shown in the Fig. Q.6.3.

5.7 : Diode Equation

Q.7 State the diode current equation and explain the meaning of each term in it.

Q [JNTU : Part A, Dec.-06, 11, 17, 18, May-05, 14, Marks 2]

Ans. : • The relationship between applied voltage V and the diode current I is mathematically given by the equation called diode current equation.

$$I = I_0 [e^{V/\eta V_T} - 1] \text{ A}$$

where I_0 = Reverse saturation current in amperes,

V = Applied voltage

η = 1 for germanium diode and = 2 for silicon diode

V_T = Voltage equivalent of temperature in volts

- The voltage equivalent of temperature indicates dependence of diode current on temperature.
- The voltage equivalent of temperature V_T at temperature T is calculated as,

$$V_T = kT \text{ volts where } k = \text{Boltzmann's constant} \\ = 8.62 \times 10^{-5} \text{ eV/}^\circ\text{K,} \\ T = \text{Temperature in } ^\circ\text{K}$$

- At room temperature of 27 °C i.e. $T = 27 + 273 = 300^\circ\text{K}$ the value of V_T is $.62 \times 10^{-5} \times 300 = 0.02586 \text{ V} = 26 \text{ mV.}$

Important Points to Remember

- The diode current equation is applicable for all the conditions of diode i.e. unbiased, forward biased and reverse biased.

While using the diode current equation :

For forward biased, V must be taken positive and we get current I positive which is forward current.

For reverse biased, V must be taken negative and we get negative current I which indicates that it is reverse current

Q.8 For what voltage will the current in p-n junction Germanium diode reach 90 % of its saturation value at room temperature ?

Q [JNTU : Part A, Dec.-17, Marks 2]

Ans. : $\eta = 1$ for Ge, $I = 90\% I_0$, $V_T = 26 \text{ mV}$

$$I = I_0 [e^{V/\eta V_T} - 1]$$

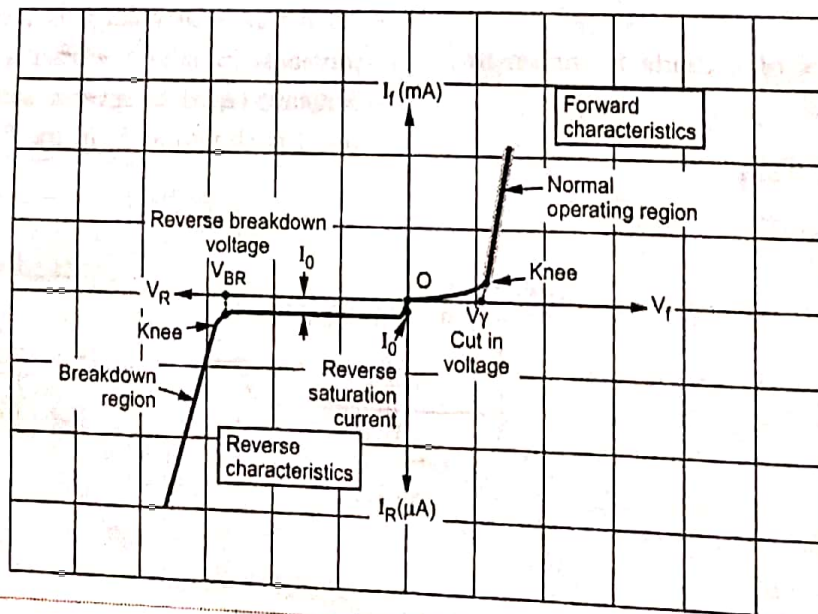

Fig. Q.6.3 Complete V-I characteristics of a diode

$$0.9 I_0 = I_0 [e^{V/1 \times 26 \times 10^{-3}} - 1]$$

$$\therefore e^{V/26 \times 10^{-3}} = 1.9 \quad \text{i.e.} \quad \frac{V}{26 \times 10^{-3}} = \ln[1.9]$$

$$\therefore V = 16.69 \text{ mV}$$

Q.9 The voltage across a silicon diode at room temperature (300 °K) is 0.7 V when 2 mA current flows through it. If the voltage increases to 0.75 V, calculate the new diode current.

[JNTU : Part B, Dec.-13, May-04, Marks 5]

Ans. : $V = 0.7 \text{ V}$, $T = 300 \text{ °K}$, $I = 2 \text{ mA}$, $\eta = 2$ for Si

$$I = I_0 (e^{V/\eta V_T} - 1),$$

$$V_T = 26 \text{ mV at } 300 \text{ °K}$$

$$\therefore 2 \times 10^{-3} = I_0 (e^{0.7/2 \times 26 \times 10^{-3}} - 1)$$

$$\text{i.e. } I_0 = 2.8494 \text{ nA}$$

Hence current at $V = 0.75 \text{ V}$ is,

$$I = 2.8494 \times 10^{-9} [e^{0.75/2 \times 26 \times 10^{-3}} - 1]$$

$$= 5.2313 \text{ mA}$$

Q.10 Write the diode current equation and mention how it supports reverse biased condition.

[JNTU : Part A, Aug.-18, Marks 2]

OR Justify the nature of V-I characteristics of diode from its current equation.

Ans. : Consider a current equation of a diode as,

$$I = I_0 (e^{V/\eta V_T} - 1)$$

• For forward biased condition, the bias voltage V is positive hence $e^{V/\eta V_T} \gg 1$ due to positive sign of exponential index. Hence neglecting '1'.

$$I_f = I_0 e^{V/\eta V_T}$$

• This justifies that forward characteristics is exponential in nature.

• For reverse biased condition, V is treated negative hence exponential index has negative sign. Hence $e^{-V/\eta V_T} \ll 1$ and can be neglected to get,

$$I_R = I_0 (-1) = -I_0$$

• This justifies that the reverse current is constant and equal to reverse saturation current. The negative sign indicates that it flows in opposite direction to that of I_f .

5.8 : Static and Dynamic Resistance of Diode

Q.11 Define forward and reverse resistance of a diode. [JNTU : Part A, Aug.-17, Marks 2]

Ans. : • The resistance offered by a diode to its forward current is called forward resistance of a diode. It is in the range of few ohms.

• The resistance offered by a diode to its reverse saturation current is called reverse resistance of a diode. It is in the range of few mega ohms.

Q.12 Differentiate between static and dynamic resistances of a diode.

[JNTU : Part B, April-18, Aug.-18, May-19, Marks 5]

Ans. :

1. **Static resistance** : This is the resistance of p-n junction diode when p-n junction is used in d.c. circuit and the applied forward voltage is d.c. Hence this is also called d.c. resistance of a diode. This resistance is denoted as R_f and is calculated at a particular point on the forward characteristics as the ratio of the forward voltage to the forward current at that point.

$$R_f = \frac{\text{Forward d.c. voltage at a point}}{\text{Forward d.c. current at the same point}}$$

2. **Dynamic resistance** : The resistance offered by the p-n junction under a.c. conditions is called dynamic resistance denoted as r_f . It is also called a.c. resistance of a diode.

• If ΔV_f is the change in applied voltage and ΔI_f is the corresponding change in the forward current then $\Delta I_f / \Delta V_f$ is the slope of the characteristics. The reciprocal of the slope is nothing but the dynamic resistance r_f .

$$r_f = \frac{\Delta V_f}{\Delta I_f} = \frac{1}{(\Delta I_f / \Delta V_f)}$$

$$= \frac{1}{\text{Slope of forward characteristics}}$$

The static and dynamic resistances are shown in the Fig. Q.12.1.

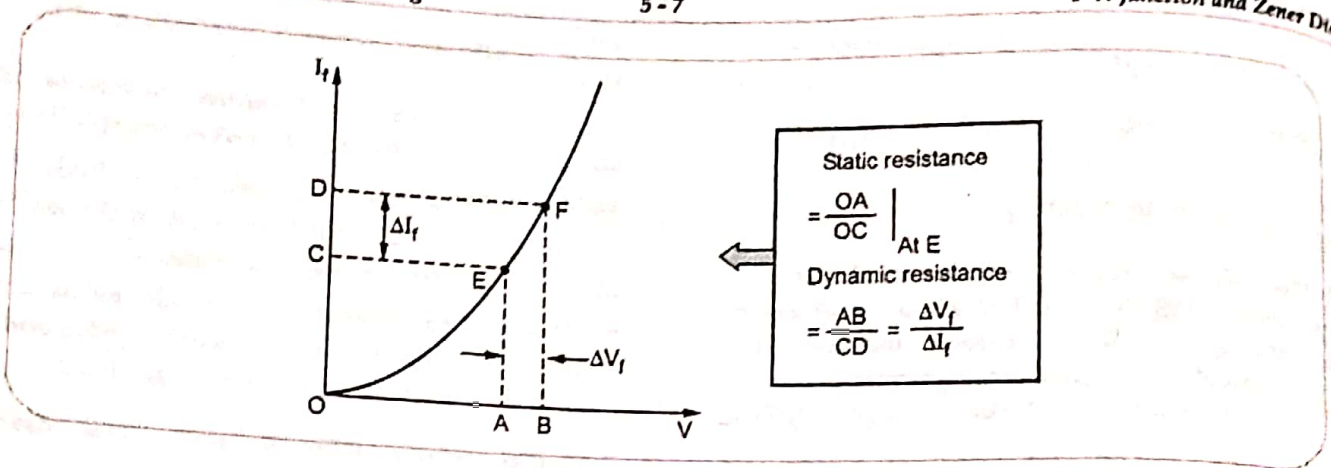

Fig. Q.12.1

Important Points to Remember

Mathematical Expression for Diode Resistance

$$r = \frac{\eta V_T}{I_0 e^{V/\eta V_T}}$$

- Use +ve sign for V while calculating forward resistance and use -ve sign for V while calculating reverse resistance.

Q.13 For a Ge diode, the $I_0 = 2 \mu\text{A}$ and the voltage of 0.26 V is applied. Calculate the forward and reverse dynamic resistance values at room temperature.

[JNTU : Part B, Jan.-10, 14, Aug.-06, May-12, Dec.-12, 16, Marks 5]

Ans. : $V = 0.26 \text{ V}, I_0 = 2 \mu\text{A}, \eta = 1$ for Ge

$$r = \frac{\eta V_T}{I_0 e^{V/\eta V_T}} \quad \therefore V_T = 26 \text{ mV}$$

For forward resistance, V is + 0.26 V,

$$\therefore r_f = \frac{1 \times 26 \times 10^{-3}}{2 \times 10^{-6} e^{0.26/26 \times 10^{-3}}} = 0.5902 \Omega$$

For reverse resistance, V is - 0.26 V,

$$\therefore r_r = \frac{1 \times 26 \times 10^{-3}}{2 \times 10^{-6} e^{-0.26/26 \times 10^{-3}}} = 286.344 \text{ M}\Omega$$

5.9 : Temperature Dependence of Diode

Q.14 Draw the V-I characteristics of p-n junction diode and show the shift with increase in temperature.

[JNTU : Part A, Dec.-07, 14, May- 11, 18, 19, Marks 3]

OR How reverse saturation current vary with the temperature ?

[JNTU : Part A, Dec.-18, Marks 2]

- Ans: The temperature has following effects on the diode parameters,
1. The cut-in voltage decreases as the temperature increases. The diode conducts at smaller voltages at large temperature.
 2. The reverse saturation current increases as temperature increases.

$$I_{02} = 2^{(\Delta T/10)} I_{01} \quad \dots \Delta T = (T_2 - T_1)$$

where I_{02} = Reverse current at T_2 °C
 and I_{01} = Reverse current at T_1 °C

3. The voltage equivalent of temperature V_T also increases as temperature increases.
4. The reverse breakdown voltage increases as temperature increases.
5. At higher temperatures, as the device junction temperature is higher, it can dissipate less power.

Thus maximum power dissipation of the device decreases at higher temperatures.

The effect of temperature on the diode characteristics is shown in the Fig. Q.14.1.

Q.15 The reverse saturation current of a silicon diode is 5 mA at a room temperature of 27 °C. Find the reverse saturation current at i) 40 °C and ii) 60 °C.

[JNTU : Part A, Dec.-10, Marks 3]

Ans:

$$I_{01} = 5 \text{ mA}, t_1 = 27 \text{ }^\circ\text{C}.$$

i) $t_2 = 40 \text{ }^\circ\text{C}, \Delta t = t_2 - t_1 = 13$

$$I_{02} = (2^{\Delta T/10}) \times I_{01}$$

$$= 2^{1.3} \times 5 = 12.3114 \text{ mA}$$

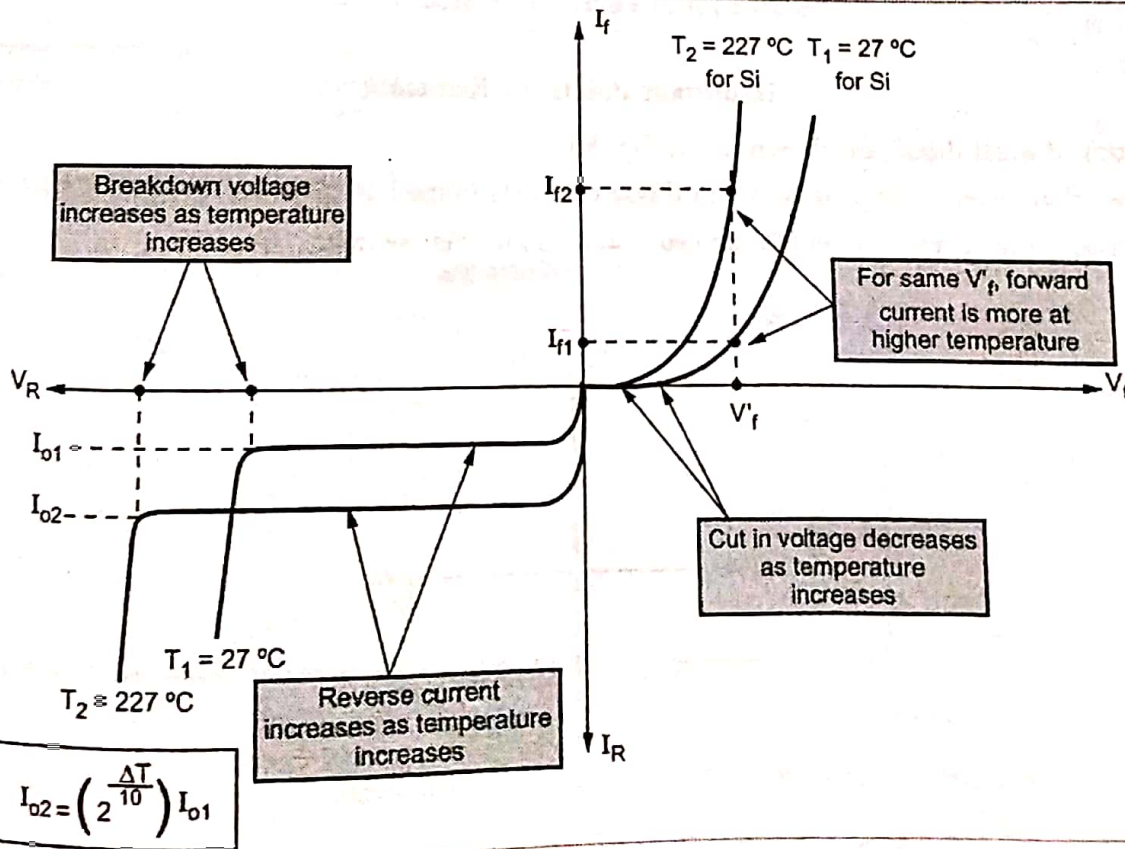

Fig. Q.14.1 Effect of temperature on diode characteristics

$$\text{ii) } t_2 = 60 \text{ }^\circ\text{C}, \Delta t = 60 - 27 = 33$$

$$I_{02} = (2^{33/10}) \times 5 = 49.245 \text{ mA}$$

Q.16 The reverse saturation current of germanium diode is $100 \mu\text{A}$ at $27 \text{ }^\circ\text{C}$. Find the forward current for $V = 0.2 \text{ V}$. If temperature is increased by $20 \text{ }^\circ\text{C}$, find the new forward current for same voltage of $V = 0.2 \text{ V}$. [JNTU : Part B, Dec.-04, Marks 5]

Ans. : $I_{01} = 100 \mu\text{A}$, $t_1 = 27 \text{ }^\circ\text{C}$, $V = 0.2 \text{ V}$, $V_T = 26 \text{ mV}$, $\eta = 1$ for G_e

$$\begin{aligned} \therefore I_1 &= I_{01} [e^{V/\eta V_T} - 1] \\ &= 100 \times 10^{-6} [e^{0.2/1 \times 26 \times 10^{-3}} - 1] = 219.042 \text{ mA} \end{aligned}$$

New temperature is $t_2 = 27 + 20 = 47 \text{ }^\circ\text{C}$

$$T_2 = 47 + 273 = 320 \text{ }^\circ\text{K}$$

$$\begin{aligned} \therefore V_{T2} &= 8.62 \times 10^{-5} \times T_2 \\ &= 8.62 \times 10^{-5} \times 320 = 27.58 \text{ mV} \end{aligned}$$

$$I_{02} = 2^{\Delta T/10} \times I_{01}, \quad \Delta T = t_2 - t_1 = 20$$

$$\therefore I_{02} = 2^{20/10} \times 100 = 400 \mu\text{A}$$

$$\begin{aligned} \therefore I_2 &= I_{02} [e^{V/\eta V_{T2}} - 1] \\ &= 400 \times 10^{-6} [e^{0.2/1 \times 27.58 \times 10^{-3}} - 1] = 563.76 \text{ mA} \end{aligned}$$

...New current

5.10 : Ideal Versus Practical Diode

Important Points To Remember

- Characteristics of ideal diode are shown in the Fig. 5.1.
- It can be seen that cut-in voltage is zero and diode conducts immediately when forward biased.
- In reverse biased, the reverse current is zero so it acts as an open switch.

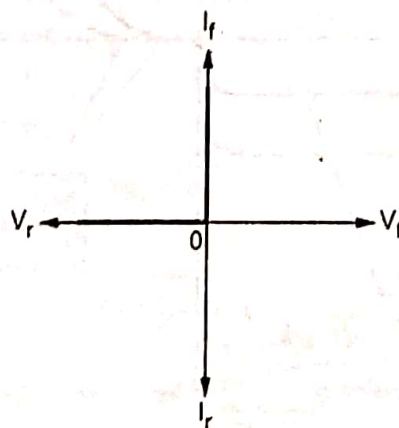

Fig. 5.1

Q.17 Compare ideal and practical diode.

Ans. :

Sr. No.	Ideal diode	Practical diode
1.	The cut-in voltage is zero.	It has finite but small cut-in voltage.
2.	The internal forward resistance is zero.	It has small finite internal forward resistance.
3.	The voltage drop across forward biased ideal diode is zero.	There is finite voltage drop across forward biased practical diode.
4.	It acts as a short circuit (closed switch) in forward biased condition.	It does not act as a short circuit in forward biased condition.
5.	The internal resistance is infinite in reverse biased condition.	The internal resistance is very high but finite in reverse biased condition.
6.	It acts as an open circuit (open switch) in reverse biased condition.	It does not act as an open circuit in reverse biased condition. It carries very small reverse current.
7.	It does not exist in practice.	All the diodes are practical diodes.

5.11 : Equivalent Circuits of Diode

Q.18 Explain the second and third approximations of diode.

Ans. : **Second approximation of diode** : Practically the dynamic resistance of a diode is very small and is neglected. Due to this, the diode forward voltage drop is assumed constant equal to cut-in voltage of the diode. Thus the forward voltage drop of silicon diode is assumed constant equal to its cut-in voltage of 0.7 V while that of germanium diode is of 0.3 V. The reverse current is very small and neglected hence the diode is assumed to be open circuit in reverse biased condition. The second approximation characteristics is shown in the Fig. Q.18.1.

Third approximation of diode : The approximation of characteristics with the help of pieces of straight lines is called third approximation or linear piecewise approximation.

- To obtain this approximation, $V_f = V_T = V_Y$ (cut in voltage) is marked on the voltage axis and then a straight line is drawn with a slope equal to the reciprocal of the dynamic resistance (r_d) of the diode.
- Thus the approximation consists of two straight lines, one horizontal and other with slope $(1/r_d)$ as shown in the Fig. Q.18.2.

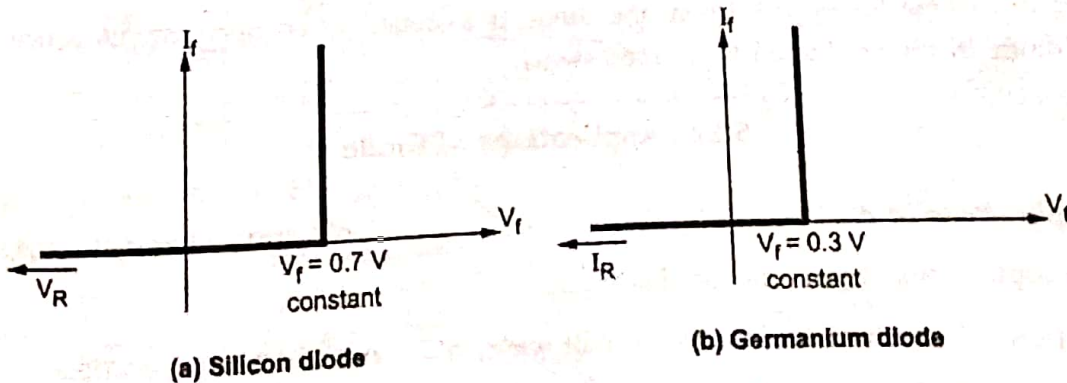

Fig. Q.18.1 Second approximation of diode

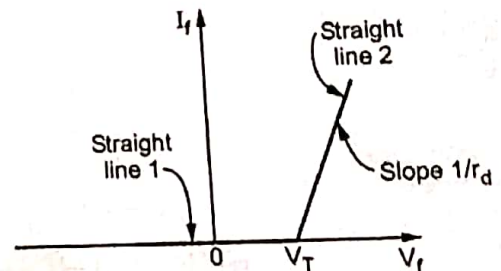

Fig. Q.18.2 Linear piecewise approximation

[JNTU : Part A, March-17, Marks 3]

Q.19 Draw the various equivalent circuits of a diode.

OR Draw the equivalent circuit of an ideal diode and that of a piecewise linear model.

[JNTU : Part A, May-18, Marks 2]

OR Draw the equivalent circuit and V-I characteristics of an ideal and piecewise linear model of a diode.

[Part B, May-19, Marks 5]

Ans. : For the analysis of various circuits, it is necessary to replace the diode by a battery and resistance depending on the approximation. This circuit is called equivalent circuit or circuit model of diode. In all such circuit models the reverse biased diode is assumed to be open circuited.

Type	Model in forward biased	V-I characteristics	Drop across diode
Ideal diode	 $r_f = 0, V_Y = 0$		$V_f = 0$
Piecewise linear with $r_f = 0 \Omega$	 V_Y $r_f = 0$		$V_f = V_Y$
Piecewise linear with finite r_f	 V_Y r_f I_f D		$V_f = V_Y + I_f r_f$

Table Q.19.1 Diode equivalent circuits

Practically in reverse biased condition, the diode is assumed to be open circuit hence the equivalent circuit of diode in reverse biased is an open switch.

5.12 : Applications of Diode

Q.20 State the applications of diode.

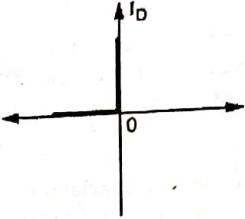
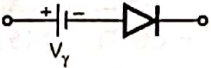
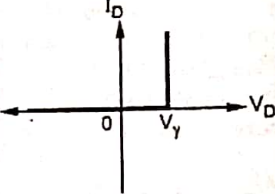
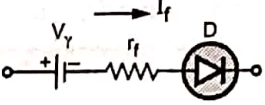
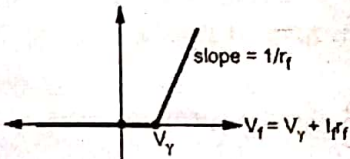
[JNTU : Part A, Dec.-08, May-12, Marks 2]

Ans. : The various applications of p-n junction diode are,

1. Rectifiers which are further classified as half wave, full wave and bridge rectifiers.
2. Clipper circuits to remove unwanted portions of waveform.
3. Clamper circuits to add d.c. level to waveform.

4. Voltage multipliers such as voltage doubler, voltage tripler etc.
5. Various electronic and operational amplifier circuits such as voltage to current converters, log and antilog amplifiers, precision rectifiers, protection circuits etc.

5.13 : Load Line Analysis of Diode

Q.21 Draw the load line on the V-I characteristics of a diode and state its significance.
 [JNTU : Part B, Aug.-17, Marks 5]

Ans. : Consider simple diode circuit shown in the Fig. Q.21.1.

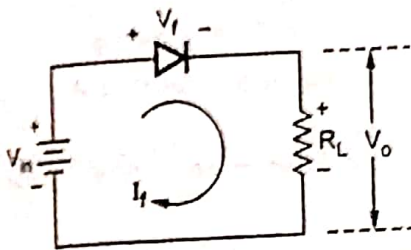

Fig. Q.21.1

- The graphical analysis which gives precise relationship between V_f and I_f without using diode approximation is called d.c. load line analysis of a diode.

• Applying kVL, $V_f = V_{in} - I_f R_L$

i.e. $I_f = -\frac{V_f}{R_L} + \frac{V_{in}}{R_L}$... (Q.21.1)

- The equation (Q.16.1) is called equation of d.c. load line. It is straight line of slope $-1/R_L$.
- For d.c. load line analysis, draw the line as per equation (Q.21.1) on the diode characteristics given in the datasheet.

• For this, the two points are,

Point A, $V_f = 0$ V, $I_f = \frac{V_{in}}{R_L}$ A

Point B, $I_f = 0$ A, $V_f = V_{in}$ V

- The line joining points A and B is called d.c. load line of a diode.
- This is shown in the Fig. Q.21.2.
- **Q Point** : There exists only one point on the d.c. load line as per the forward characteristics of the diode. It is the intersection of the forward characteristics and d.c. load line of the diode. This is called **operating point, quiescent point or Q point** of the device.
- It is also called d.c. biasing point for the diode.

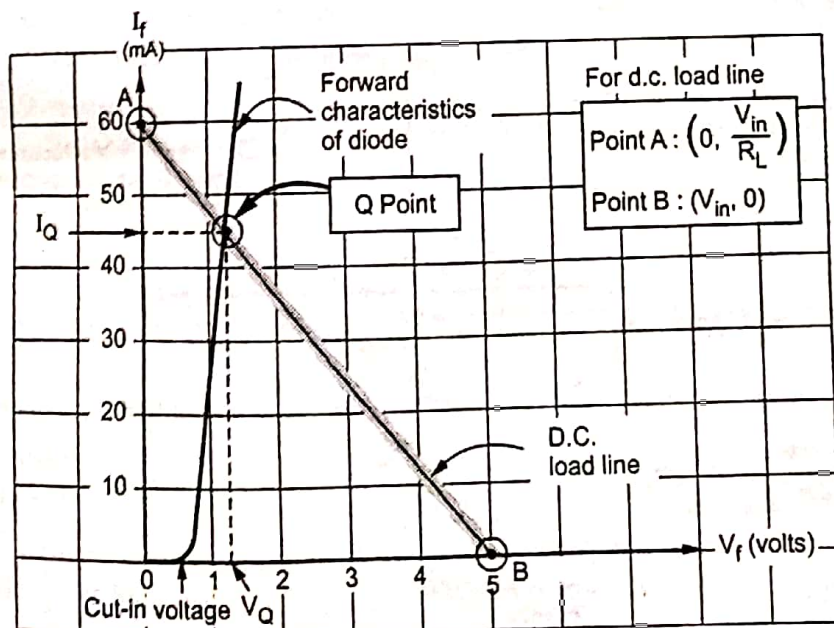

Fig. Q.21.2 D.C. load line analysis of diode

5.14 : Zener Diode

Q.22 What is zener diode ? Draw the V-I characteristics of a Zener diode and show the breakdown region. [JNTU : Part B, Dec.-05,14,16, May-08,13,18, Marks 5]

[JNTU : Part A, March-17, Marks 2]

OR Draw V-I characteristics of zener diode.

Ans. : • A zener diode is a silicon p-n junction semiconductor device which is operated in its reverse breakdown region.

- The zener diodes are fabricated with precise breakdown voltages by controlling the doping level during manufacturing.
- The Fig. Q.22.1 (a) shows the symbol of zener diode while the Fig. Q.22.1 (b) shows the the operation of zener diode in reverse breakdown region.
- When the reverse voltage is applied to zener diode, at a certain reverse voltage, the reverse breakdown occurs and current in the zener diode increases rapidly. The sharp change in the zener current is called knee or zener knee of the reverse characteristics.
- The reverse bias voltage at which the breakdown occurs is called zener breakdown voltage, denoted as V_Z . This value is carefully designed by controlling the doping level during manufacturing.
- The V-I characteristics of zener diode is shown in the Fig. Q.22.2.
- For zener diodes, practically two currents are specified. The I_{Zmin} is minimum current through the zener diode to maintain its reverse breakdown operation.
- The I_{Zmax} is the maximum current which zener diode can take safely maintaining its reverse breakdown operation, i.e. constant V_Z across it.



(a) Symbol

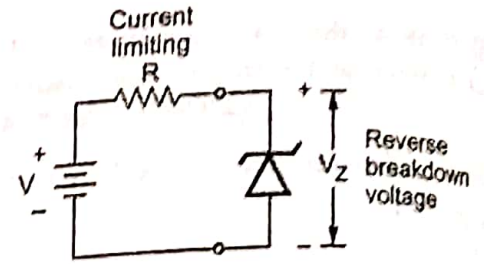

(b) Reverse biasing

Fig. Q.22.1 Zener diode

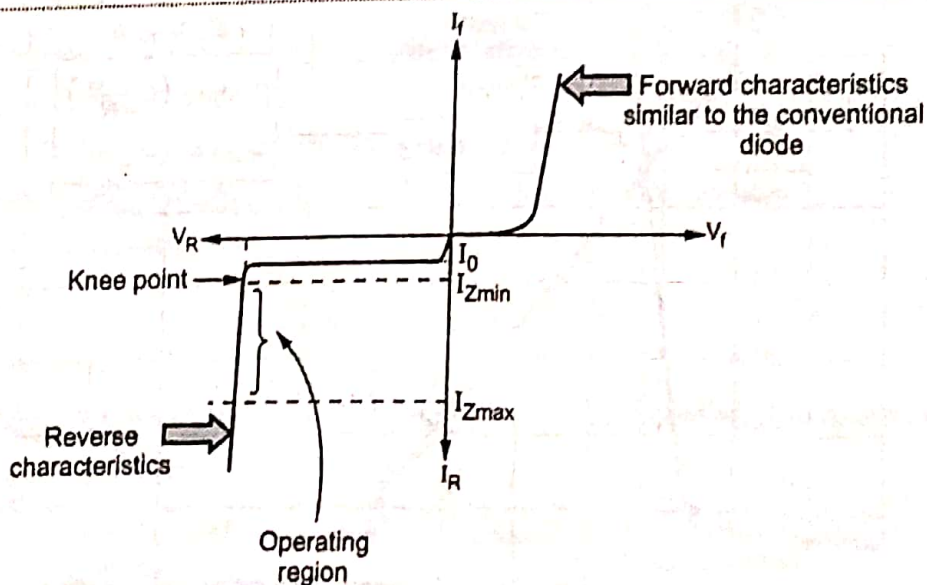

Fig. Q.22.2 V-I Characteristics of zener diode

Q.23 Explain the avalanche and zener breakdown mechanisms.

[JNTU : Part B, Dec.-12, 14, 16, March-17, Marks 5]

OR Explain the zener breakdown mechanisms.

[JNTU : Part A, Aug.-17, Marks 3]

Ans. : Breakdown due to the avalanche Effect :

- If reverse voltage is increased, at a particular value, velocity of minority carriers increases.
- Due to the kinetic energy associated with the minority carriers, more minority carriers are generated when there is collision of minority carriers with the atoms. The collision make the electrons to break the co-valent bonds.
- These electrons are available as minority carriers and get accelerated due to high reverse voltage. They again collide with another atoms to generate more minority carriers. This is called carrier multiplication.
- Finally large number of minority carriers move across the junction, breaking the p-n junction. These large number of minority carriers give rise to a very high reverse current.
- This effect is called avalanche effect and the mechanism of destroying the junction is called reverse breakdown of a p-n junction. The voltage at which the breakdown of a p-n junction occurs is called reverse breakdown voltage.

Breakdown due to the Zener Effect :

- When a p-n junction is heavily doped the depletion region is very narrow.
 - Electric field is voltage per distance and due to narrow depletion region and high reverse voltage, it is intense.
 - Such an intense field is enough to pull the electrons out of the valence bands of the stable atoms.
 - Such a creation of free electrons is called zener effect which is different than the avalanche effect. These minority carriers constitute very large current and mechanism is called zener breakdown.
- These effects are required to be considered for special diodes such as zener diode as such diodes are always operated in reverse breakdown condition.

Compare between zener and avalanche breakdown.

[JNTU : Part A, May-09, Dec.-12, Marks 3]

Sr. No.	Zener breakdown	Avalanche breakdown
1.	Breakdown is due to intense electric field across the junction.	Breakdown is due to the collision of accelerated charge carriers with the adjacent atoms and due to carrier multiplication.
2.	Occurs for zeners with zener voltage less than 6 V.	Occurs for zeners with zener voltage greater than 6 V.
3.	The temperature coefficient is negative.	The temperature coefficient is positive.
4.	The breakdown voltage decreases as junction temperature increases.	The breakdown voltage increases as junction temperature increases.
5.	The V-I characteristics is very sharp in breakdown region.	The V-I characteristics is not as sharp as zener breakdown.

Q.25 Compare zener diode with conventional p-n junction diode.

[JNTU : Part A, May-12, Dec.-08, Marks 3]

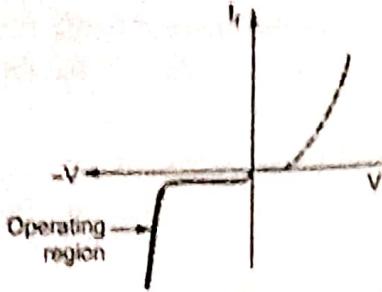
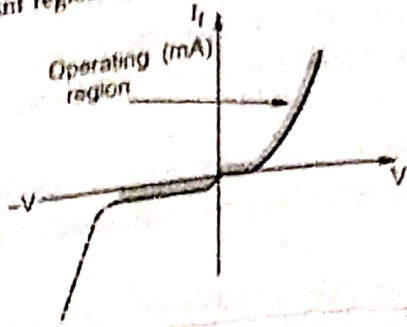
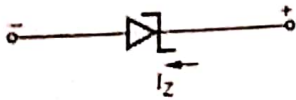
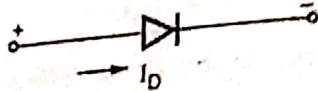
No.	Zener diode	P-N Junction diode
1.	Operated in reverse breakdown condition.	Operated in forward biased condition and never operated in reverse breakdown condition.
2.	The important region of operation lies in third quadrant. 	The important region of operation lies in first quadrant. 
3.	Dynamic zener resistance is very small in reverse breakdown condition.	The diode resistance in reverse biased condition is very high.
4.	Zener diode symbol is. 	The p-n junction diode symbol is, 
5.	The conduction in zener is opposite to that of arrow in the symbol, as operated in breakdown region.	The conduction when forward biased is in same direction as that of arrow in the symbol, when forward biased.
6.	The power dissipation capability is very high.	The power dissipation capability is very low compared to zener diodes.
7.	Applications of zener diode are voltage regulator, protection circuits, voltage limiters etc.	Applications of p-n junction diode are rectifiers, voltage multipliers, clippers, clampers and many electronic devices.

5.15 : Zener Diode as Regulator

Important Points to Remember

- A circuit used after the filter circuit in a power supply which makes the d.c. output voltage smooth and ripple free and keeps it constant irrespective of changes in the load or in input line voltage is called voltage regulator.

Q.26 Explain how zener diode acts as a voltage regulator.

[JNTU : Part B, May-06, 09, 11, 19, Dec. -08, 12, 14, 17, Marks 5]

OR Justify the statement : ' A zener diode can be used as a voltage regulator.'

[JNTU : Part B, Aug.-17, March-16, Marks 5]

Ans. : • A shunt voltage regulator using zener diode is shown in the Fig. Q.26.1. (See Fig. Q.26.1 on next page).

- The zener diode has a characteristics that as long as the current through it is between I_{Zmin} and I_{Zmax} , the voltage across it is constant equal to zener voltage V_Z .
- As zener diode is connected in shunt with the load resistance, the output voltage is equal to the zener voltage.

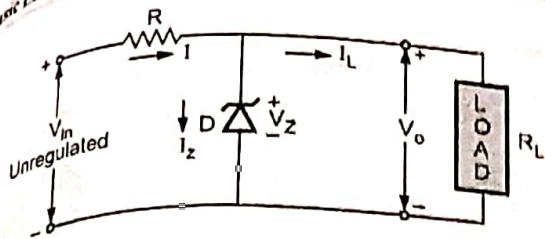

Fig. Q.26.1 Zener diode as a shunt regulator

From the Fig. Q.26.1 we can write,

$$V_o = V_Z \quad \text{and} \quad I = I_Z + I_L$$

Regulation with varying input voltage :

The load current $I_L = \frac{V_o}{R_L} = \frac{V_Z}{R_L} = \text{constant}$ and

$$I = I_Z + I_L$$

If V_{in} increases, then the total current I increases. But I_L is constant as V_Z is constant. Hence the current I_Z increases to keep I_L constant.

Similarly if V_{in} decreases, then current I decreases. But to keep I_L constant, I_Z decreases.

But in both cases, as long as I_Z is between I_{Zmin} and I_{Zmax} , the V_Z i.e. output voltage V_o is constant.

Thus the changes in input voltage get compensated and output is maintained constant.

Regulation with varying load :

The input voltage is constant while the load resistance R_L is variable.

As V_{in} is constant and $V_o = V_Z$ is constant, then for constant R the current I is constant.

$$\therefore I = \frac{V_{in} - V_Z}{R} \text{ constant} = I_L + I_Z$$

If R_L decreases, I_L increases and to keep I constant I_Z decreases accordingly. But as long as it is between I_{Zmin} and I_{Zmax} , output voltage V_o will be constant.

Similarly if R_L increases, I_L decreases and to keep I constant I_Z increases accordingly. But as long as it is between I_{Zmin} and I_{Zmax} , output voltage V_o will be constant.

Thus the changes in the load get compensated and output is maintained constant.

Q.27 What are the limitations of zener voltage regulator circuit ? [JNTU : Part A, May-19, Marks 2]

- Ans. :
1. Large power loss in series resistance.
 2. Poor efficiency due to power loss.
 3. The d.c. output voltage changes due to zener resistance.
 4. Changes in I_L produce changes in zener current.
 5. The output voltage is not adjustable as $V_o = V_Z$.
 6. Can not be used for large load currents.

Q.28 State the applications of zener diode.

[JNTU : Part B, May-09, Marks 2]

Ans. : • The various applications of zener diode are,

1. As a voltage regulator.
2. In voltage clipper circuits.
3. For controlling the output amplitude.
4. As a reference voltage in comparator circuits.
5. As a standard voltage source in calibrating the instruments.
6. In various protection circuits.
7. For amplitude limiting in oscillator circuits.
8. In various types of wave shaping circuits.

Q.29 For a zener regulator shown in the Fig. Q.29.1, calculate the range of input voltage for which output will remain constant.

$V_Z = 6.1 \text{ V}$, $I_{Zmin} = 2.5 \text{ mA}$,
 $I_{Zmax} = 25 \text{ mA}$, $r_z = 0 \Omega$

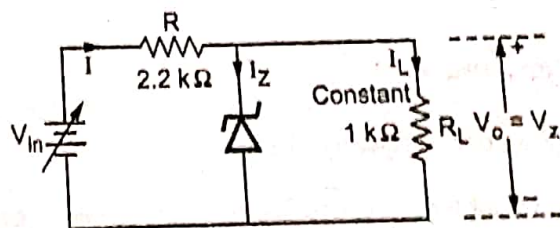

Fig. Q.29.1

Ans. : $R_L = 1 \text{ k}\Omega$, $V_Z = 6.1 \text{ V}$

$$\therefore I_L = \frac{V_Z}{R_L} = \frac{6.1}{1 \times 10^3} = 6.1 \text{ mA constant}$$

For $V_{in(min)}$, $I_Z = I_{Zmin} = 2.5 \text{ mA}$

$$\therefore I = I_{Zmin} + I_L = 2.5 + 6.1 = 8.6 \text{ mA}$$

$$\begin{aligned}\therefore V_{\text{in(min)}} &= V_Z + IR = 6.1 + 8.6 \times 10^{-3} \times 2.2 \times 10^3 \\ &= 25.02 \text{ V}\end{aligned}$$

$$\text{For } V_{\text{in(max)}} \quad I_Z = I_{Z\text{max}} = 25 \text{ mA}$$

$$\therefore I = I_{Z\text{max}} + I_L = 25 + 6.1 = 31.1 \text{ mA}$$

$$\begin{aligned}\therefore V_{\text{in(max)}} &= V_Z + IR = 6.1 + 31.1 \times 10^{-3} \times 2.2 \times 10^3 \\ &= 74.52 \text{ V}\end{aligned}$$

Thus the range of input voltage is 25.02 V to 74.52 V, for which output will be constant.

Note : MCQ and Fill in the Blanks of Unit-IV are given after Chapter 6.

END... ✂

6

Rectifiers and Filters

6.1 : Rectifiers

Q.1 What is need of rectifier ? List different types of rectifiers.

[JNTU : Part A, Dec.-09, 12, 18, March-17, Marks 2]

Ans. : In many electronic circuits, d.c. supply is required to provide power supply to many components.

• Practically d.c. supply is to be obtained from available a.c. supply.

• The p-n junction diode conducts in only one direction. In forward biased condition it conducts heavily while in reversed biased condition it is practically acts as open circuit and does not conduct at all. Hence alternating voltage when applied to diode, the output varies only in one direction and hence p-n junction diode can be conveniently used to convert a.c. supply to d.c. supply.

• A circuit which is used to convert a.c. voltage into pulsating d.c. voltage using one or more p-n junction diodes is called a **rectifier**.

• Thus the rectifier is very much essential component of many electronic circuits.

• The various types of rectifiers are,

1. Half wave rectifier
2. Full wave rectifier using 2 diodes and
3. Bridge rectifier

6.2 : Half Wave Rectifier

Q.2 With a neat circuit diagram and necessary wave forms explain the operation of half wave rectifier.

[JNTU : Part B, May-05, 08, 09, Aug.-08, Dec.-12, 13, 17, Marks 5]

Ans. : • The circuit diagram is shown in the Fig. Q.2.1.

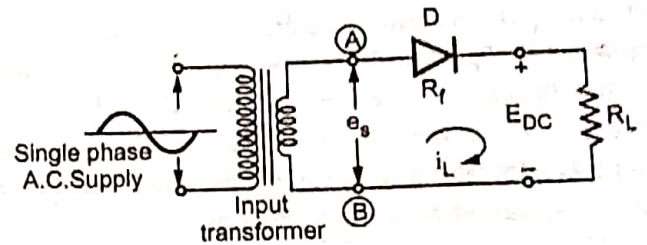

Fig. Q.2.1 Halfwave rectifier

• A sinusoidal a.c. voltage, having frequency of 50 Hz is applied to rectifier circuit using suitable step-down transformer, with necessary turns ratio.

• The transformer secondary voltage e_s is mathematically given by,

$$e_s = E_{sm} \sin \omega t$$

with $\omega = 2\pi f$ and

$f =$ Supply frequency

• The turns ratio of transformer decides the secondary voltage e_s which is applied to rectifier.

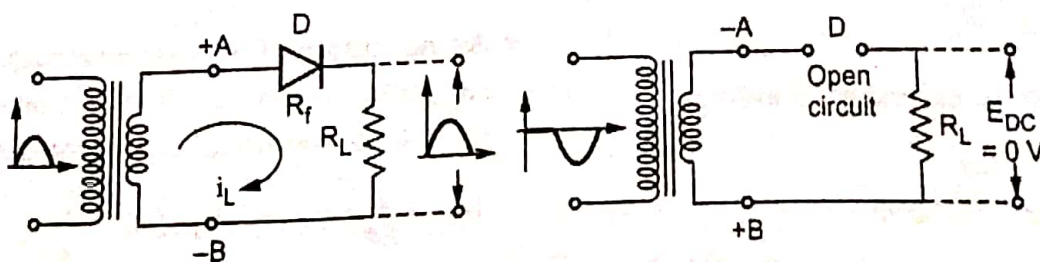

(a) Diode forward biased

(b) Diode reverse biased

Fig. Q.2.2

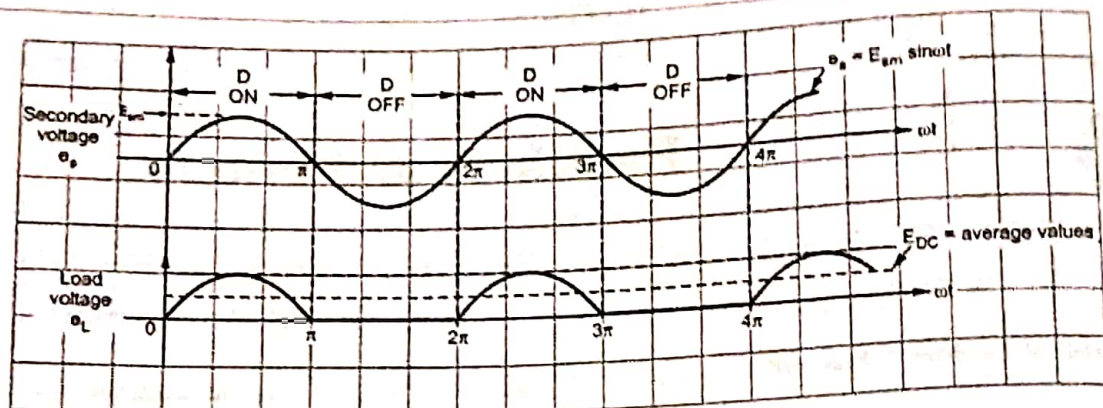

Fig. Q.2.3 Load current and load voltage waveforms for half wave rectifier

Operation of the Circuit :

- During the positive half cycle of input a.c. voltage, terminal (A) becomes positive with respect to terminal (B). The diode is forward biased and the current flows in the circuit in the clockwise direction, as shown in the Fig. Q.2.2 (a). This current is also flowing through the load resistance R_L hence denoted as i_L (load current).
- During negative half cycle when terminal (A) is negative with respect to terminal (B), diode becomes reverse biased. Thus it acts as an open circuit. Hence no current flows in the circuit as shown in the Fig. Q.2.2 (b).
- Thus the circuit current, which is also the load current, is in the form of half sinusoidal pulses.
- The load voltage, being the product of load current and load resistance, will also be in the form of half sinusoidal pulses. The different waveforms are illustrated in Fig. Q.2.3.

Important Points to Remember

- The peak value of the load current is given by,

$$\therefore I_m = \frac{E_{sm}}{R_f + R_L + R_s}$$

where R_s = Resistance of secondary winding of transformer

- R_f = Forward resistance of diode
- If R_s and R_f are not given they should be neglected while calculating I_m .

- If the transformer ratio is $N_1 : N_2$ then,

$$\frac{E_s(\text{rms})}{E_p(\text{rms})} = \frac{E_{sm}}{E_{pm}} = \frac{N_2}{N_1}$$

Where, E_s = Transform secondary voltage
 E_p = Transform primary voltage

Q.3 Derive the expression for the d.c. load current, average d.c. load voltage and r.m.s. value of load current for the half wave rectifier.

[JNTU : Part B, May-08, 09, 12, Aug.-08, Dec.-10, Marks 5]

Ans. : • The average or d.c. value of the load current (I_{DC}) : It is obtained by integration.

- Mathematically, current waveform can be described as,

$$i_L = I_m \sin \omega t \quad \text{for } 0 \leq \omega t \leq \pi$$

$$\text{and } i_L = 0 \quad \text{for } \pi \leq \omega t \leq 2\pi$$

where I_m = Peak value of load current

$$\therefore I_{DC} = \frac{1}{2\pi} \int_0^{2\pi} i_L d(\omega t) = \frac{1}{2\pi} \int_0^{\pi} I_m \sin(\omega t) d(\omega t)$$

- As no current flows during negative half cycle of a.c. input voltage, i.e. between $\omega t = \pi$ to $\omega t = 2\pi$ we change the limits of integration.

$$\begin{aligned} \therefore I_{DC} &= \frac{1}{2\pi} \int_0^{\pi} I_m \sin(\omega t) d(\omega t) = \frac{I_m}{2\pi} [-\cos(\omega t)]_0^{\pi} \\ &= -\frac{I_m}{2\pi} [\cos(\pi) - \cos(0)] = -\frac{I_m}{2\pi} [-1 - 1] = \frac{I_m}{\pi} \end{aligned}$$

$$I_{DC} = \frac{I_m}{\pi} = \text{Average value}$$

The average d.c. load voltage (E_{DC}): It is the product of average D.C. load current and the load resistance R_L .

$$E_{DC} = I_{DC} R_L = \frac{I_m}{\pi} R_L = \frac{E_{sm}}{(R_f + R_L + R_s) \pi} R_L$$

- The winding resistance R_s and forward diode resistance R_f are practically very small compared to R_L hence neglecting them,

$$E_{DC} \approx \frac{E_{sm}}{\pi}$$

The RMS value of the load current (I_{RMS}):

- The RMS means squaring, finding mean and then square root. Mathematically it is obtained as,

$$I_{RMS} = \sqrt{\frac{1}{2\pi} \int_0^{2\pi} (I_m \sin \omega t)^2 d(\omega t)} = \sqrt{\frac{1}{2\pi} \int_0^{\pi} I_m^2 \sin^2 \omega t d(\omega t)}$$

$$= I_m \sqrt{\frac{1}{2\pi} \int_0^{\pi} \frac{1 - \cos 2\omega t}{2} d(\omega t)} = I_m \sqrt{\frac{1}{2\pi} \left\{ \frac{\omega t}{2} - \frac{\sin 2\omega t}{4} \right\}_0^{\pi}} = I_m \sqrt{\frac{1}{2\pi} \left(\frac{\pi}{2} \right)} = \frac{I_m}{2} \quad \dots \sin(2\pi) = \sin(0) = 0$$

$$I_{RMS} = \frac{I_m}{2} \text{ and } E_{L(RMS)} = I_{RMS} R_L = \frac{I_m}{2} R_L = \frac{E_{sm}}{2}$$

Q.4 Define ripple factor. State its expression. Obtain its value for half wave rectifier.

[JNTU : Part A, March-16, Dec.-16, May- 13, 17, Marks 3]

- Mathematically ripple factor is defined as the ratio of R.M.S. value of the a.c. component in the output to average or d.c. component present in the output.

$$\text{Ripple factor } \gamma = \frac{\text{R. M. S. value of a.c. component of output}}{\text{Average or d.c. component of output}}$$

$$\text{Ripple factor} = \frac{I_{ac}}{I_{DC}} = \frac{\sqrt{I_{RMS}^2 - I_{DC}^2}}{I_{DC}} = \sqrt{\left(\frac{I_{RMS}}{I_{DC}} \right)^2 - 1}$$

...As per definition

- This is the general expression for ripple factor and can be used for any rectifier circuit.

- For a half wave circuit, $I_{RMS} = \frac{I_m}{2}$ while $I_{DC} = \frac{I_m}{\pi}$

$$\gamma = \sqrt{\left[\left(\frac{I_m}{2} \right)^2 \right] - 1} = \sqrt{\frac{\pi^2}{4} - 1} = \sqrt{1.4674} = 1.21$$

... Halfwave

Q.5 Define PIV and TUF.

[JNTU : Part A, Dec.-14, Marks 2]

Ans. : PIV : It is the peak inverse voltage appearing across the diode in the reverse direction when the diode is in reverse biased condition. This is also called PIV rating of the diode. For half wave rectifier PIV rating of the diode is E_{sm} .

TUF : It is transformer utilization factor of the circuit. It is defined as the ratio of d.c. power delivered to the load to the a.c. power rating of the transformer used.

Mathematically it is given by,

$$TUF = \frac{\text{D.C. power delivered to the load}}{\text{A.C. power rating of the transformer}}$$

Q.6 Define the percentage voltage regulation.

[JNTU : Part A, Dec.-16, 18, May-18, Marks 2]

Ans. : • The voltage regulation is the factor which tells us about the change in the d.c. output voltage as load changes from no load to full load condition.

- If $(V_{dc})_{NL}$ = D.C. voltage on no load and $(V_{dc})_{FL}$ = D.C. voltage on full load then voltage regulation is defined as,

$$\therefore \% \text{ Voltage regulation} = \frac{(V_{dc})_{NL} - (V_{dc})_{FL}}{(V_{dc})_{FL}} \times 100$$

- Less the value of voltage regulation, better is the performance of rectifier circuit.

Q.7 Derive the expression for the efficiency of the half wave rectifier and prove that the maximum efficiency is 40.6 %.

[JNTU : Part B, Dec.-14, Marks 5]

Ans. : The a.c. power input to half wave rectifier is given by,

$$P_{AC} = I_{RMS}^2 (R_s + R_f + R_L)$$

$$I_{RMS} = \frac{I_m}{2} = \frac{E_{sm}}{(R_s + R_f + R_L) \times 2}$$

$$\therefore P_{AC} = \frac{E_{sm}^2}{4(R_s + R_f + R_L)}$$

$$P_{DC} = I_{DC}^2 R_L = \left[\frac{E_{sm}}{(R_s + R_f + R_L) \pi} \right]^2 R_L$$

$$\therefore \% \eta = \frac{P_{DC}}{P_{AC}} \times 100 \text{ and using above,}$$

$$\% \eta = \left[\frac{\frac{4}{\pi^2} R_L}{R_f + R_L + R_s} \right] \times 100$$

Practically, $(R_f \text{ and } R_s) \ll R_L$ hence neglect $R_f + R_s$ from the denominator to get the maximum efficiency.

$$\therefore \% \eta_{max} = \frac{\frac{4}{\pi^2} \times R_L}{R_L} \times 100 = 40.6 \%$$

Thus the maximum efficiency of half wave rectifier is 40.6 %.

Q.8 A single phase half wave rectifier operates from 230 V, 50 Hz supply. The load resistance is 5 kΩ. Find out the output voltage and current.

[JNTU : Part B, May-17, Marks 5]

Ans. :

$$R_L = 5 \text{ k}\Omega, E_s(\text{RMS}) = 230 \text{ V}$$

$$\therefore E_{sm} = \sqrt{2} \times E_s(\text{RMS}) = 325.269 \text{ V}$$

$$I_m = \frac{E_{sm}}{R_L} = \frac{325.269}{5 \times 10^3} = 65.054 \text{ mA}$$

$$\therefore I_{DC} = \frac{I_m}{\pi} = \frac{65.054}{\pi} = 20.707 \text{ mA}$$

$$\therefore E_{DC} = I_{DC} R_L = 103.537 \text{ V}$$

Q.9 A sinusoidal voltage whose $V_m = 12 \text{ V}$ is applied to half-wave rectifier. The diode may be considered to be ideal and $R_L = 1.5 \text{ k}\Omega$ is connected as load. Find out peak value of current, RMS value of current, DC value of current and ripple factor.

[JNTU : Part B, Dec.-12,14,16, March-16, Marks 5]

$$\text{Ans. : } V_m = E_{sm} = 12 \text{ V}, R_L = 1.5 \text{ k}\Omega$$

$$I_m = \frac{E_{sm}}{R_L} = 8 \text{ mA}$$

$$I_{RMS} = \frac{I_m}{2} = 4 \text{ mA}$$

$$I_{DC} = \frac{I_m}{\pi} = 2.546 \text{ mA}$$

$$r = \sqrt{\left[\frac{I_{RMS}}{I_{DC}} \right]^2} - 1 = 1.211$$

Q.10 A diode whose internal resistance is 20Ω is in supply power to a 100Ω load from 110 V (R.M.S.) source of supply. Calculate : i) Peak load current, ii) DC load current, iii) AC load current, iv) % regulation from no load to given load.

[JNTU : Part B, Dec.-16, May-19, Marks 6]

Ans. : Single diode means half wave rectifier.

$$R_L = 100 \Omega, R_f = 20 \Omega, R_s = 0 \Omega$$

$$E_{sm} = \sqrt{2} \times E_s (\text{RMS})$$

$$= \sqrt{2} \times 110 = 155.563 \text{ V}$$

$$I_m = \frac{E_{sm}}{R_L + R_f + R_s} = 1.2963 \text{ A}$$

$$I_{DC} = \frac{I_m}{\pi} = 0.4126 \text{ A}$$

$$I_{RMS} = \frac{I_m}{2} = 0.6481 \text{ A}$$

$$E_{DC} = I_{DC} R_L = 0.4126 \times 100$$

$$= 41.26 \text{ V} = (E_{DC})_L$$

$$(E_{DC})_{NL} = \frac{E_{sm}}{\pi} = 49.517 \text{ V}$$

$$\% R = \frac{(E_{DC})_{NL} - (E_{DC})_L}{(E_{DC})_L} \times 100 = 20.01 \%$$

Q.11 An ac supply of 220 V is applied to a half wave rectifier circuit through a transformer with a turns ratio of $10 : 1$. Assume the ideal diode.

Find - i) dc output voltage, ii) PIV.

[JNTU : Part B, Dec.-17, Marks 5]

$$\text{Ans. : } E_{p(\text{rms})} = 220 \text{ V}, \frac{N_1}{N_2} = 10 : 1$$

$$\frac{E_{s(\text{rms})}}{E_{p(\text{rms})}} = \frac{N_2}{N_1} = \frac{1}{10}$$

$$E_{s(\text{rms})} = \frac{220}{10} = 22 \text{ V}$$

$$E_{sm} = \sqrt{2} E_{s(\text{rms})} = 31.112 \text{ V}$$

i) For ideal diode,

$$E_{DC} = \frac{E_{sm}}{\pi} = 9.903 \text{ V}$$

$$\text{ii) } \text{PIV} = E_{sm} = 31.112 \text{ V}$$

6.3 : Full Wave Rectifier

Q.12 Draw the circuit diagram of full wave rectifier with centre tapped transformer and explain its operation. State the PIV rating of the diode.

[JNTU : Part B, May-08, 09, 13, March-16, Dec.-11, 12, 13, 16, Aug.-18, Marks 5]

Ans. : • The full wave rectifier circuit is shown in the Fig. Q.12.1.

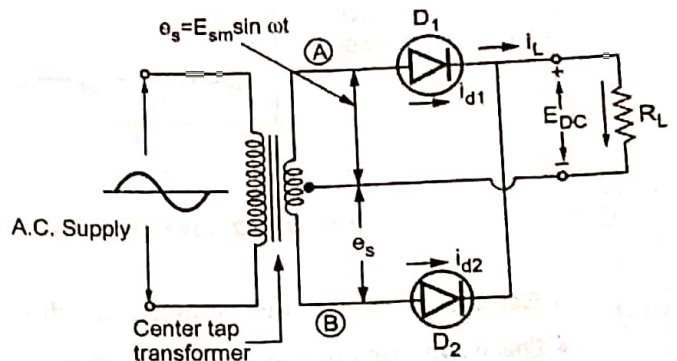

Fig. Q.12.1 Full wave rectifier

- It uses a center tap transformer.
- It uses two diodes which feed a common load resistance R_L .
- The a.c. voltage is applied through a suitable power transformer with proper turns ratio.

Operation of the Circuit :

- Consider the positive half cycle of ac input voltage in which terminal (A) is positive and terminal (B) is negative due to center tap transformer.
- The diode D_1 will be forward biased and hence will conduct; while diode D_2 will be reverse biased and will act as an open circuit and will not conduct. The diode D_1 supplies the load current, i.e. $i_L = i_{d1}$.
- In the next half cycle of ac voltage, polarity reverses and terminal (A) becomes negative and (B) positive. The diode D_2 conducts, being forward biased, while D_1 does not, being reverse biased. The diode D_2 supplies the load current, i.e. $i_L = i_{d2}$.
- The load current flows in both the half cycles of ac voltage and in the same direction through the load resistance. Hence we get rectified output across the load.

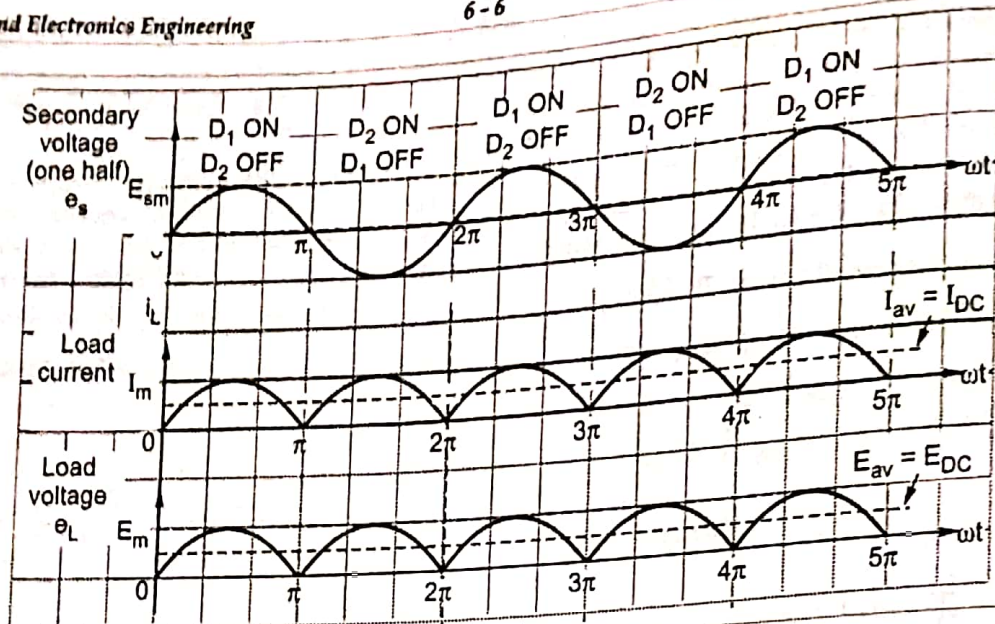

Fig. Q.12.2 Load current and voltage waveforms for full wave rectifier

- The load current is sum of individual diode currents flowing in corresponding half cycles.
- The waveforms of secondary voltage (one half), load current and load voltage are shown in the Fig. Q.12.2.

PIV : When one diode is reverse biased then the net voltage across the reverse biased diode is the full voltage across the entire secondary of the transformer which is $2E_{sm}$. Hence the PIV rating of the diode in centre tap full wave rectifier is $2E_{sm}$.

Important Points to Remember

- R_f = Forward resistance of diodes and R_L = Load resistance
- R_s = Winding resistance of each half of secondary
- E_{sm} = Maximum value of a.c. input voltage across each half of secondary winding
- The maximum value of the load current, $I_m = \frac{E_{sm}}{R_s + R_f + R_L}$.

Q.13 Derive the expressions for d.c. load voltage, d.c. load current and the rms current of full wave rectifier.

☞ [JNTU : Part B, May-06, Sept.-06, 08, Dec.-14, Marks 5]

Ans. : The average or d.c. value of the load current (I_{DC}) :

- Consider one cycle of the load current i_L from 0 to π to obtain the average value which is d.c. value of load current.

$$i_L = I_m \sin \omega t \quad 0 \leq \omega t \leq \pi$$

$$I_{av} = I_{DC} = \frac{1}{\pi} \int_0^{\pi} i_L d(\omega t) = \frac{1}{\pi} \int_0^{\pi} I_m \sin \omega t d\omega t$$

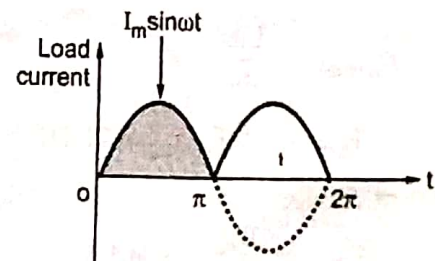

Fig. Q.13.1 Load current waveform

$$= \frac{I_m}{\pi} \left[(-\cos \omega t) \Big|_0^\pi \right] = \frac{I_m}{\pi} [-\cos \pi - (-\cos 0)] = \frac{I_m}{\pi} [1 - (-1)] \quad \because \cos \pi = -1$$

$$I_{DC} = \frac{2I_m}{\pi}$$

Average DC Load Voltage (E_{DC}):

The d.c. load voltage is, $E_{DC} = I_{DC} R_L = \frac{2I_m R_L}{\pi}$

Substituting value of I_m ,

$$E_{DC} = \frac{2 E_{sm} R_L}{\pi [R_f + R_s + R_L]} = \frac{2 E_{sm}}{\pi \left[1 + \frac{R_f + R_s}{R_L} \right]}$$

• But as R_f and $R_s \ll R_L$ hence $\frac{R_f + R_s}{R_L} \ll 1$,

$$E_{DC} = \frac{2E_{sm}}{\pi}$$

RMS Load Current (I_{RMS}): Mathematically it can be obtained as,

$$I_{RMS} = \sqrt{\frac{1}{2\pi} \int_0^{2\pi} i_L^2 d(\omega t)} = \sqrt{2 \times \frac{1}{2\pi} \int_0^\pi [I_m \sin(\omega t)]^2 d(\omega t)}$$

• The circuit has two half wave rectifiers similar in operation operating in two half cycles hence integration term is splitted as above.

$$I_{RMS} = I_m \sqrt{\frac{1}{\pi} \int_0^\pi \sin^2(\omega t) d(\omega t)} = I_m \sqrt{\frac{1}{\pi} \int_0^\pi \frac{1 - \cos 2\omega t}{2} d(\omega t)} = I_m \sqrt{\frac{1}{\pi} \left[\frac{\omega t}{2} - \frac{\sin(2\omega t)}{4} \right]_0^\pi} = I_m \sqrt{\frac{1}{\pi} \left[\frac{\pi}{2} \right]}$$

$$I_{RMS} = \frac{I_m}{\sqrt{2}} \text{ and } E_{L(RMS)} = I_{RMS} R_L = \frac{I_m}{\sqrt{2}} R_L$$

Q.14 For a full wave rectifier, show that its maximum efficiency is 81.2%.

[JNTU : Part B, March-14, Dec.-04, 11, May-07, Aug.-18, Marks 5]

Ans. : Maximum theoretical efficiency :

• D.C. Power output = $E_{DC} I_{DC} = I_{DC}^2 R_L$

$$P_{DC} = \left(\frac{2I_m}{\pi} \right)^2 R_L = \frac{4}{\pi^2} \frac{E_{sm}^2}{(R_s + R_f + R_L)^2} \times R_L = \frac{4}{\pi^2} I_m^2 R_L$$

$$AC \text{ power input } P_{AC} = I_{RMS}^2 (R_f + R_s + R_L)$$

$$= \left(\frac{I_m}{\sqrt{2}} \right)^2 (R_f + R_s + R_L) = \frac{I_m^2 (R_f + R_s + R_L)}{2}$$

• Substituting value of I_m we get

$$P_{AC} = \frac{E_{sm}^2}{(R_f + R_s + R_L)^2} \times \frac{1}{2} \times (R_f + R_s + R_L) = \frac{E_{sm}^2}{2(R_f + R_s + R_L)}$$

$$\text{Rectifier efficiency } \eta = \frac{P_{DC} \text{ output}}{P_{AC} \text{ input}} = \frac{\frac{4}{\pi^2} I_m^2 R_L}{\frac{I_m^2 (R_f + R_s + R_L)}{2}} = \frac{8 R_L}{\pi^2 (R_f + R_s + R_L)}$$

• But if $R_f + R_s \ll R_L$, neglecting it from denominator,

$$\eta_{max} = \frac{8 R_L}{\pi^2 (R_L)} = \frac{8}{\pi^2}$$

$$\% \eta_{max} = \frac{8}{\pi^2} \times 100 = 81.2 \%$$

Q.15 Derive the ripple factor for full wave rectifier.

[JNTU : Part A, Dec.-17, Aug.-18, Marks 2]

Ans. : Ripple factor :

• The ripple factor is given by a general expression,

$$\text{Ripple factor} = \sqrt{\left[\frac{I_{RMS}}{I_{DC}} \right]^2 - 1}$$

• For full wave $I_{RMS} = I_m / \sqrt{2}$ and $I_{DC} = 2I_m / \pi$ so substituting above,

$$\therefore \text{Ripple factor} = \gamma = \sqrt{\left[\frac{I_m / \sqrt{2}}{2I_m / \pi} \right]^2 - 1} = \sqrt{\frac{\pi^2}{8} - 1} = 0.48$$

• This indicates that the ripple contents in the output are 48 % of the d.c. component which is much less than that for the half wave circuit.

Q.16 A single phase full wave rectifier operates from 230 V, 50 Hz supply. The load resistance is 10 kΩ. Draw the waveforms of all the diode currents and represent the values.

[JNTU : May-17, Marks 5]

Ans. : $E_s(\text{RMS}) = 230 \text{ V}$, $R_L = 10 \text{ k}\Omega$

$$E_{sm} = \sqrt{2} E_s(\text{RMS}) = 325.269 \text{ V}$$

$$I_m = \frac{E_{sm}}{R_L} = 32.527 \text{ mA}$$

$$I_{DC} = \frac{2I_m}{\pi} = 20.707 \text{ mA}$$

$$E_{DC} = I_{DC} R_L = 207.072 \text{ V}$$

The waveforms are shown in the Fig. Q.16.1.

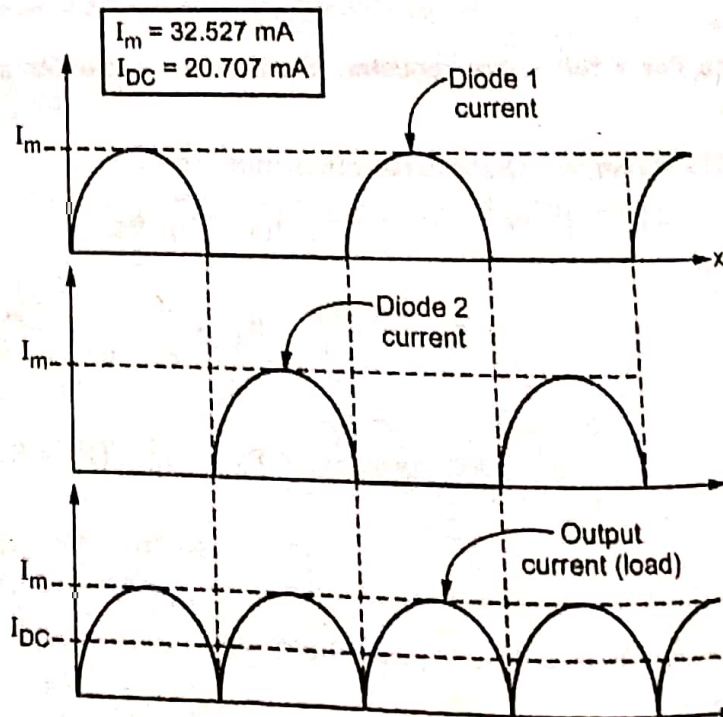

Fig. Q.16.1

Q.17 A full wave rectifier circuit uses two silicon diodes with a forward resistance of 20Ω each. A DC voltmeter connected across the load of $1 \text{ k}\Omega$ reads 55.4 volts. Calculate

- i) I_{rms} ii) Average voltage across each diode
 iii) Ripple factor iv) Transformer secondary voltage rating.

[JNTU : May-12, 09, Dec.-04]

Ans :

$$R_f = 20 \Omega, \quad R_L = 1 \text{ k}\Omega, \quad E_{\text{DC}} = 55.4 \text{ V}$$

$$I_{\text{DC}} = \frac{E_{\text{DC}}}{R_L} = \frac{55.4}{1 \times 10^3} = 55.4 \text{ mA}$$

$$I_{\text{DC}} = \frac{2I_m}{\pi} \quad \text{i.e.} \quad I_m = \frac{\pi \times 55.4 \times 10^{-3}}{2} = 87.022 \text{ mA}$$

$$\text{i) } I_{\text{rms}} = \frac{I_m}{\sqrt{2}} = \frac{87.022}{\sqrt{2}} = 61.5338 \text{ mA}$$

$$\text{ii) Average voltage across each diode} = I_{\text{DC}} R_f = 1.108 \text{ V}$$

$$\text{iii) } \gamma = \sqrt{\left(\frac{I_{\text{rms}}}{I_{\text{DC}}}\right)^2 - 1} = \sqrt{\left(\frac{61.5338}{55.4}\right)^2 - 1} = 0.4834$$

$$\text{iv) } I_m = \frac{E_{\text{sm}} - \text{Diode drop}}{R_f + R_L}$$

$$\text{i.e. } E_{\text{sm}} = 87.022 \times 10^{-3} \times 1020 + 1.108 = 89.87 \text{ V}$$

$$\therefore E_s (\text{rms}) = \frac{E_{\text{sm}}}{\sqrt{2}} = 63.548 \text{ V}$$

Q.18 State the advantages and disadvantages of centre tapped full wave rectifier.

[JNTU : Part A, May-07, Dec.-11, Marks 3]

Ans : Advantages and Disadvantages of Full Wave Rectifier

- The advantages of full wave rectifier are,
 1. The d.c. load voltage and current are more than half wave.
 2. No d.c. current through transformer windings hence no possibility of saturation.
 3. T.U.F. is better as transformer losses are less.
 4. The efficiency is higher.
 5. The large d.c. power output.
 6. The ripple factor is less.
- The disadvantages of full wave rectifier are,
 1. The PIV rating of diode is higher.
 2. Higher PIV diodes are larger in size and costlier.
 3. The cost of centre tap transformer is higher.

6.4 : Full Wave Bridge Rectifier

Q.19 Draw the circuit diagram of full wave bridge rectifier and explain its operation with waveforms.

[JNTU : Part B, May-06, 08, 09, 13, 19, Dec.-13, March-16, Mark

OR Draw the circuit of full wave bridge rectifier with load.

OR Show the current paths in a full wave bridge rectifier for a sinusoidal input during positive and negative half cycles. [JNTU : Part A, April-18, Marks 3]

Ans. : • The basic bridge rectifier circuit is shown in Fig. Q.19.1.

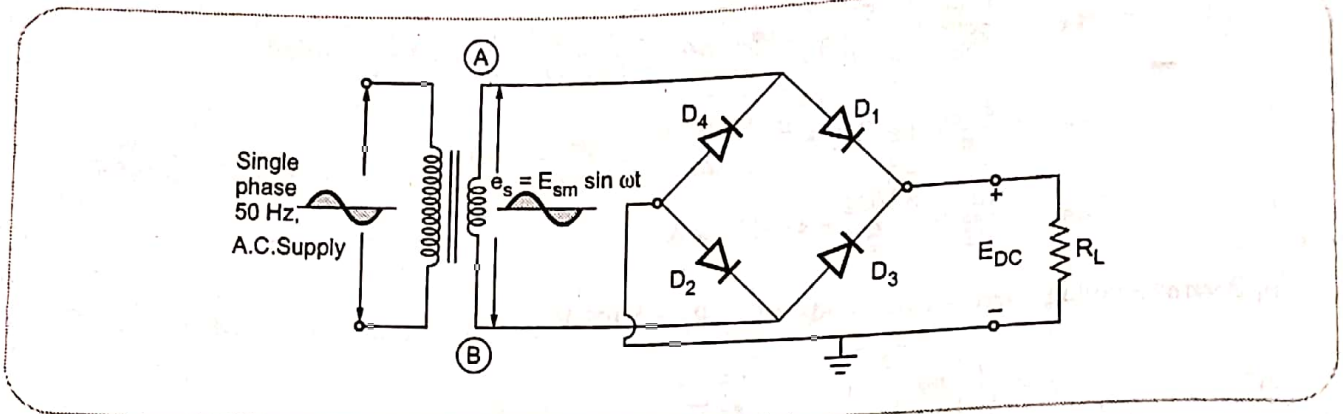

Fig. Q.19.1 Bridge rectifier circuit

- The bridge rectifier circuit is essentially a full-wave rectifier circuit, using four diodes, forming the four arms of an electrical bridge.
- To one diagonal of the bridge, the ac voltage is applied through a transformer if necessary and the rectified dc voltage is taken from the other diagonal of the bridge.

Operation of the circuit :

- Consider the positive half of ac input voltage. The point A of secondary becomes positive. The diodes D_1 and D_2 will be forward biased, while D_3 and D_4 reverse biased. The two diodes D_1 and D_2 conduct in series with the load and the current flows as shown in Fig. Q.19.2.

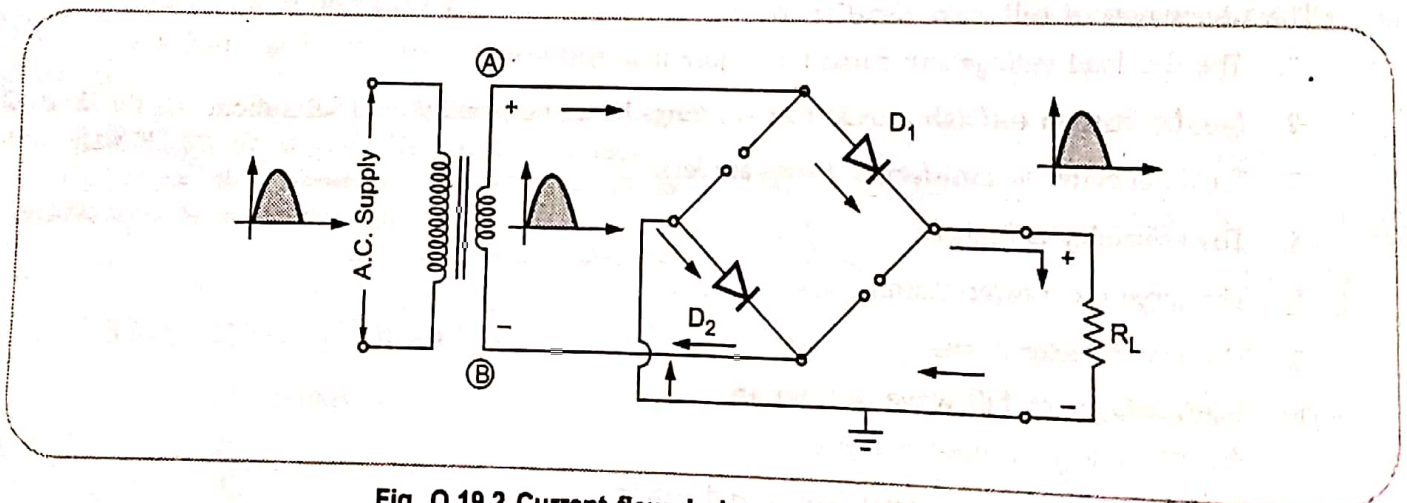

Fig. Q.19.2 Current flow during positive half cycle

- In the next half cycle, when the polarity of ac voltage reverses hence point B becomes positive diodes D_3 and D_4 are forward biased, while D_1 and D_2 reverse biased. Now the diodes D_3 and D_4 conduct in series with the load and the current flows as shown in Fig. Q.19.3.
- It is seen that in both cycles of ac, the load current is flowing in the same direction hence, we get a full-wave rectified output.

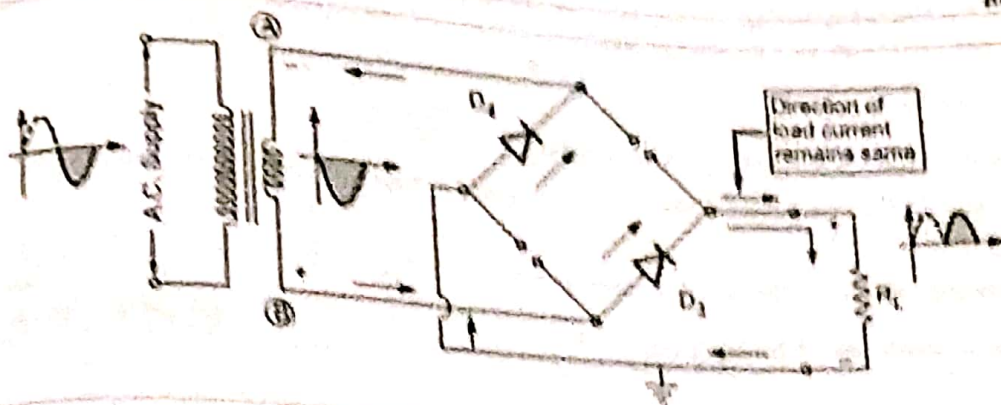

Fig. Q.19.3 Current flow during negative half cycle

The waveforms of load current and voltage are shown in the Fig. Q.19.4.

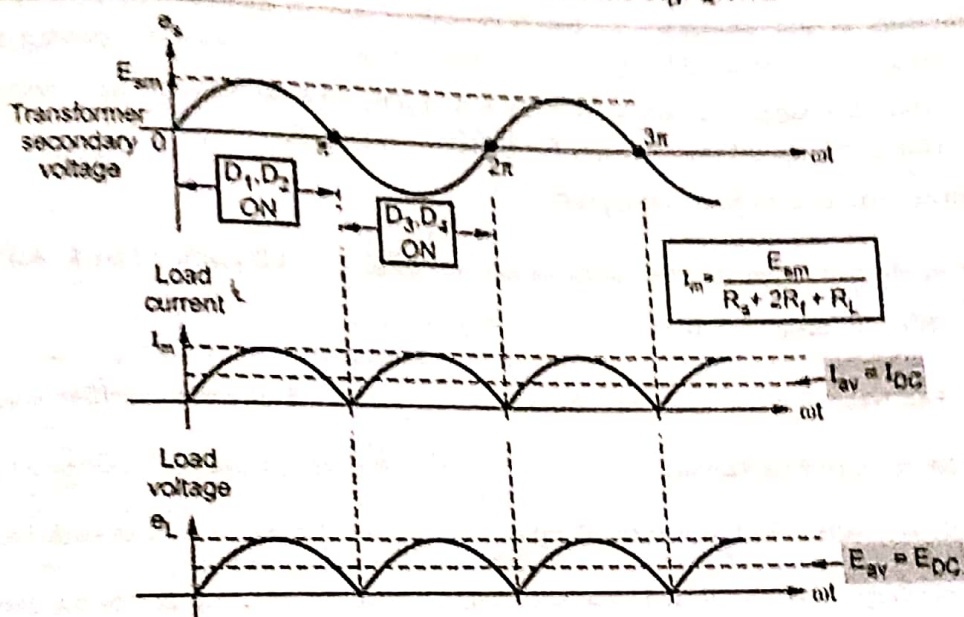

Fig. Q.19.4 Waveforms of bridge rectifier

Important Points to Remember

• For bridge rectifier, in each half cycle two diodes conduct hence in the various expressions R_f must be replaced by $2R_f$.

$$I_m = \frac{E_{sm}}{R_s + 2R_f + R_L}$$

$$E_{DC} = I_{DC} R_L = \frac{2E_{sm}}{\pi}$$

$$E_{RMS} = \frac{I_m}{\sqrt{2}} R_L = \frac{E_{sm}}{\sqrt{2}(R_s + 2R_f + R_L)} R_L$$

$$P_{DC} = I_{DC}^2 R_L = \frac{4}{\pi^2} I_m^2 R_L \quad \text{and}$$

$$P_{AC} = I_{RMS}^2 (R_s + 2R_f + R_L) = \frac{I_m^2 (2R_f + R_s + R_L)}{2}$$

$$\eta = \frac{8R_L}{\pi^2 (R_s + 2R_f + R_L)}, \quad \% \eta_{\max} = 81.2 \%$$

ripple factor $\gamma = 0.48$, T.U.F. = 0.812

- The E_{sm} is the maximum value of a.c. voltage across full secondary winding of the transformer used.
- PIV rating for the diodes used in bridge rectifier is E_{sm} .

[JNTU : Part A, Aug.-17, Marks 3]

Q.20 What are the advantages of bridge rectifier ?

Ans. : Advantages

- 1) The current in both the primary and secondary of the power transformer flows for the entire cycle and hence for a given power output, power transformer of a small size and less cost may be used.
- 2) No center tap is required in the transformer secondary.
- 3) The currents in the secondary of the transformer are in opposite directions in two half cycles. Hence net d.c. component flowing is zero which reduces the losses and danger of saturation.
- 4) As two diodes conduct in series in each half cycle, inverse voltage appearing across diodes get shared. Hence the circuit can be used for high voltage applications.
- 5) The transformer gets utilized effectively.

Q.21 Compare two diode full wave rectifier with bridge rectifier.

[JNTU : Part B, April-18, May-19, Marks 5]

Ans. : Comparison with two diode rectifier

Sr. No.	Full-wave rectifier using two diodes	Full wave rectifier using four diodes
1.	It uses centre tapped transformer.	It does not use centre tapped transformer.
2.	One diode conducts in each half cycle of input.	Two diodes conduct in each half cycle of input.
3.	The voltage drop across the diode is due to R_f only.	The voltage drop across the diodes is due to $2R_f$.
4.	The output voltage is more.	The output voltage is less.
5.	The transformer is less effectively used.	The transformer is used more effectively.
6.	TUF is 0.693.	TUF is 0.812.
7.	The PIV rating of the diode is $2 E_{sm}$.	The PIV rating of the diode is E_{sm} .

Q.22 A bridge rectifier is used to supply d.c. load of 20 A at 20 volts from 117 volts source. What is the rating of power transformer ?

[JNTU : Part A, Dec.-14, Marks 3]

Ans. :

$$I_{DC} = 20 \text{ A}, \quad E_{DC} = 20 \text{ V}$$

$$I_{DC} = \frac{2 I_m}{\pi} \quad \text{i.e.} \quad 20 = \frac{2 I_m}{\pi}$$

$$\therefore I_m = 31.416 \text{ A}$$

$$\therefore I_{RMS} = \frac{I_m}{\sqrt{2}} = 22.214 \text{ A}$$

$$I_m = \frac{E_{sm}}{R_L + R_f + R_s}$$

$$E_{sm} = I_m R_L \text{ and } R_L = \frac{P_{DC}}{I_{DC}} = 1 \Omega$$

$$E_{sm} = 31.416 \times 1 = 31.416 \text{ V}$$

$$E_s(\text{rms}) = \frac{E_{sm}}{\sqrt{2}} = 22.214 \text{ V}$$

$$\text{Rating of transformer} = E_s(\text{rms}) I_{rms} = 22.214 \times 22.214 = 493.462 \text{ VA}$$

6.5 : Comparison of Rectifiers

Compare half wave, full wave and bridge rectifier circuits.

[JNTU : Part B, March-17, Dec.-17, Marks 5]

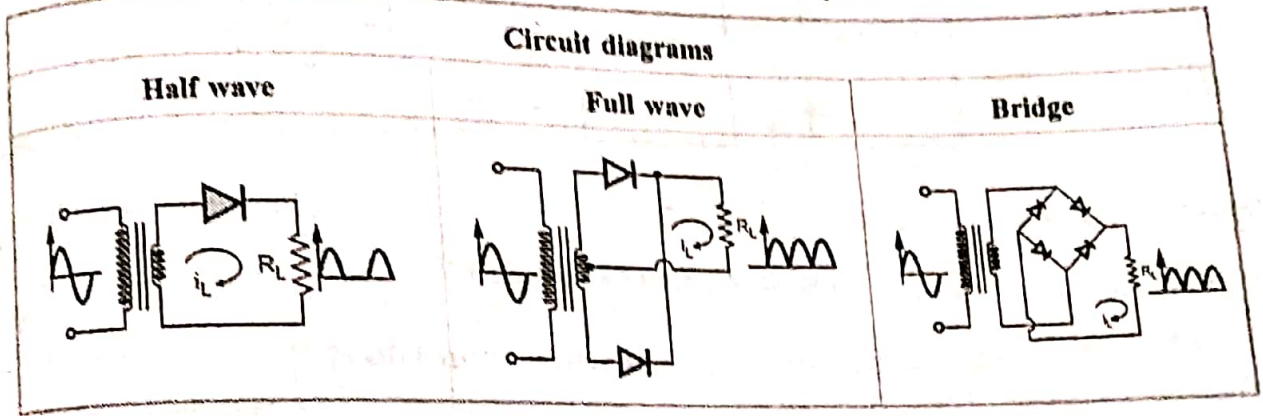

Sr. No.	Parameter	Half wave	Full wave	Bridge
1.	Number of diodes	1	2	4
2.	Average d.c. current (I_{DC})	$\frac{I_m}{\pi}$	$\frac{2I_m}{\pi}$	$\frac{2I_m}{\pi}$
3.	Average d.c. voltage (E_{DC})	$\frac{E_{sm}}{\pi}$	$\frac{2E_{sm}}{\pi}$	$\frac{2E_{sm}}{\pi}$
4.	RMS current (I_{RMS})	$\frac{I_m}{2}$	$\frac{I_m}{\sqrt{2}}$	$\frac{I_m}{\sqrt{2}}$
5.	D.C. power output (P_{DC})	$\frac{I_m^2 R_L}{\pi^2}$	$\frac{4}{\pi^2} I_m^2 R_L$	$\frac{4}{\pi^2} I_m^2 R_L$
6.	A.C. power input (P_{AC})	$\frac{I_m^2 (R_L + R_f + R_s)}{4}$	$\frac{I_m^2 (R_f + R_s + R_L)}{2}$	$\frac{I_m^2 (2R_f + R_s + R_L)}{2}$
7.	Maximum rectifier efficiency (η)	40.6 %	81.2 %	81.2 %
8.	Ripple factor (γ)	1.21	0.482	0.482
9.	Maximum load current (I_m)	$\frac{E_{sm}}{R_s + R_f + R_L}$	$\frac{E_{sm}}{R_s + R_f + R_L}$	$\frac{E_{sm}}{R_s + 2R_f + R_L}$
10.	PIV rating of diode	E_{sm}	$2 E_{sm}$	E_{sm}
11.	Ripple frequency	50 Hz	100 Hz	100 Hz
12.	T.U.F.	0.287	0.693	0.812

6.6 : Need of Filter

Q.24 What is purpose of using filters with rectifiers ?

[JNTU : Part A, March-16, 17, Dec.-12, May- 08, 11, 19, Marks 3]

Ans. : • The output of a rectifier circuit is not pure d.c.; but it contains fluctuations or ripples, which are undesired.

- To minimize the ripple content in the output, filter circuits are used.
- The filter is an electronic circuit composed of capacitor, inductor or combination of both and connected between the rectifier and the load so as to convert pulsating d.c. to pure d.c.
- The filter circuits are connected between the rectifier and load, as shown in the Fig. Q.24.1.

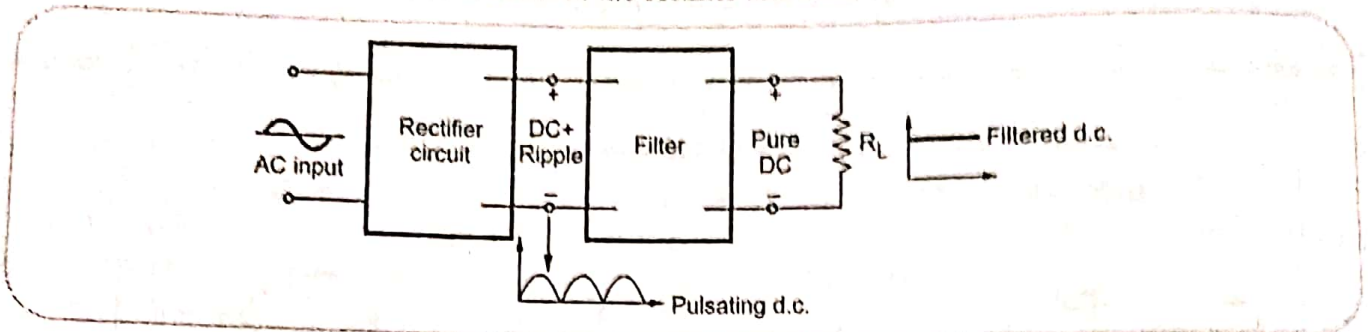

Fig. Q.24.1 Rectifier and filter

6.7 : Capacitor Filter (Capacitor Input Filter)

Important Point to Remember

- In capacitor filter circuit, a capacitor is connected in shunt with the load resistance. Looking from the rectifier side, the first element in the filter is capacitor hence it is also called capacitor input filter.

Q.25 Explain the operation of capacitor filter circuit with half wave rectifier.

[JNTU : Part B, Dec.-13,18, May- 08, Aug.-08, Marks 5]

Ans. : • The circuit diagram of half wave rectifier with shunt capacitor filter is shown in the Fig. Q.25.1.

- During the positive quarter cycle of the input, the capacitor C charges to peak value of the input i.e. E_{sm} . This is point A as shown in the Fig. Q.25.1.
- When input decreases, the C remains charged at E_{sm} and diode gets reverse biased.
- The capacitor C supplies the load R_L and starts discharging.
- Due to large time constant, capacitor discharges very little from E_{sm} .
- The capacitor supplies load for full negative half cycle and next part of positive half cycle till input is less than capacitor voltage.
- At point B, the capacitor starts charging as diode gets forward biased as input exceeds capacitor voltage.

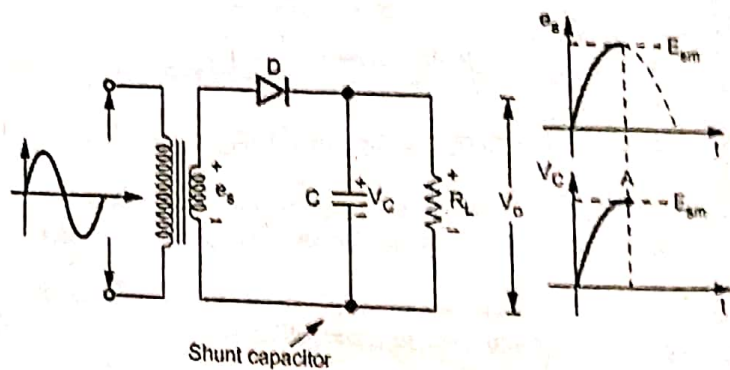

Fig. Q.25.1 Shunt capacitor filter with HWR

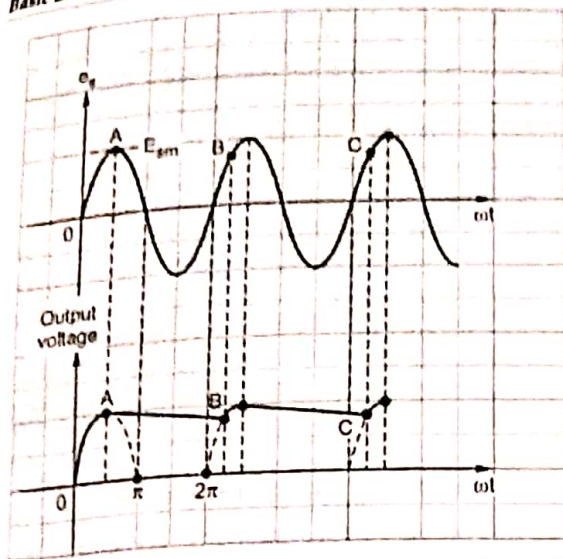

Fig. Q.25.2 Waveforms of shunt capacitor filter with HWR

- The point B is shown in the Fig. Q.25.2.
- As the discharging of capacitor is very small and charging time is very small, the ripples in the output get reduced considerably.
- The input and output waveforms are shown in the Fig. Q.25.2.

Q.26 Explain the operation of capacitor filter circuit with full wave rectifier.

[JNTU : Part B, Dec.-13, May-12, 19, Aug.-08, Marks 5]

• The Fig. Q.26.1 show the capacitor input filter with full wave rectifier.

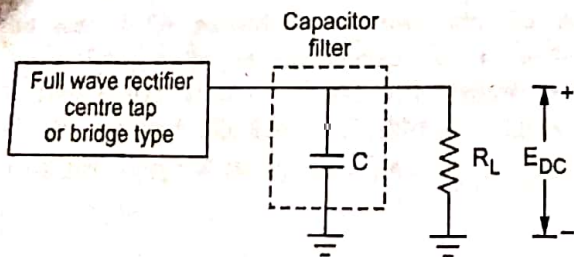

Fig. Q.26.1 Capacitor filter with full wave rectifier

- The full wave rectifier may be center tap or bridge rectifier.
- Immediately when power is turned on, the capacitor C gets charged through forward biased diode D_1 to E_{sm} during first quarter cycle of the rectified output voltage.

- In the next quarter cycle from $\frac{\pi}{2}$ to π , the capacitor starts discharging through R_L . Once capacitor gets charged to E_{sm} , the diode D_1 becomes reverse biased and stops conducting.
- So during the period from $\frac{\pi}{2}$ to π the capacitor C supplies the load current. It discharges to point B shown in the Fig. Q.26.2.

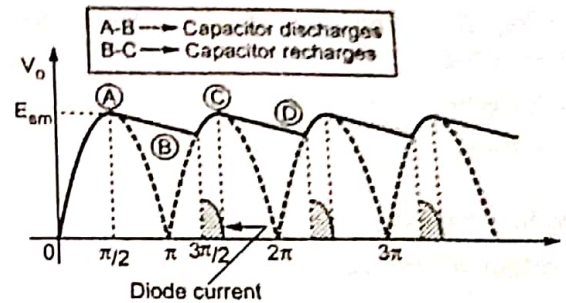

Fig. Q.26.2 FWR output with capacitor filter

- At point B, lying in the quarter π to $\frac{3\pi}{2}$ of the rectified output voltage, the input voltage exceeds capacitor voltage, making D_2 forward biased. This charges capacitor back to E_{sm} at point C.
- The time required by capacitor C to charge to E_{sm} is quite small and only for this period, diode D_2 is conducting.
- Again at point C, diode D_2 stops conducting and capacitor supplies load and starts discharging upto point D in the next quarter cycle of the rectified output voltage as shown in the Fig. Q.26.2. At this point, the diode D_1 conducts to charge capacitor back to E_{sm} . The diode currents are shown shaded in the Fig. Q.26.2.
- When the capacitor is discharging through the load resistance R_L , both the diodes are non-conducting. The capacitor supplies the load current.
- The operation remains same if full wave rectifier with two diodes is replaced with bridge rectifier. In a bridge rectifier, C charges through D_1 and D_2 in one half cycle and it recharges through D_3 and D_4 in next half cycle.

Q.27 Derive the ripple factor for capacitor filter.
 [JNTU : Part B, May-04, 18, Dec.-05, 11, 12, Marks 5]

Ans.: • Consider an output of full wave rectifier using capacitor filter as shown in the Fig. Q.27.1.

• Let T_1 = Time for which diode is conducting

T_2 = Time for which diode is non conducting

• During T_1 capacitor is charged while during T_2 it is discharged. Practically, $T_2 \gg T_1$.

• The Fig. Q.27.1 shows triangular approximation of ripple voltage.

• For triangular wave,

$$V_r(\text{rms}) = \frac{V_r}{2\sqrt{3}}$$

Where, V_r = Peak to peak ripple voltage.

• The charge lost by C during T_2 is $Q = CV_r$ But,

$$Q = \int i dt$$

$$\therefore Q = \int_0^{T_2} i dt = CV_r$$

• But, integration gives average value here

$$Q = I_{DC} T_2 = CV_r$$

$$V_r = \frac{I_{DC} T_2}{C}$$

$T = T_1 + T_2$ but, $T_2 \gg T_1$ hence $T_1 + T_2 = T_2 = \frac{T}{2}$

$$\therefore V_r = \frac{I_{DC}}{C} \left[\frac{T}{2} \right] = \frac{I_{DC}}{2Cf} \quad \dots T = \frac{1}{f}$$

$$\therefore V_r = \frac{E_{DC}}{2CfR_L} \quad \dots I_{DC} = \frac{E_{DC}}{R_L}$$

• The ripple factor is defined as,

$$\gamma = \frac{\text{rms value of ripple voltage}}{\text{d.c. value of voltage}} = \frac{V_r(\text{rms})}{E_{DC}}$$

$$\gamma = \frac{V_r / 2\sqrt{3}}{E_{DC}}$$

$$\text{i.e. } \gamma = \frac{1}{4\sqrt{3} f C R_L} \quad \dots \text{FW}$$

• For half wave, ripple factor becomes double hence,

$$\gamma = \frac{1}{2\sqrt{3} f C R_L} \quad \dots \text{HW}$$

Important Points to Remember

• The d.c. output voltage from a capacitor filter is,

$$E_{DC} = E_{sm} - I_{DC} \left[\frac{1}{4fC} \right] \text{ for full wave and}$$

$$E_{DC} = E_{sm} - I_{DC} \left[\frac{1}{2fC} \right] \text{ for half wave}$$

• The ripple voltage present in the output with capacitor filter is,

$$V_{r(\text{RMS})} = \frac{I_{DC}}{4\sqrt{3}fC} \text{ volts for full wave}$$

$$\text{and } V_{r(\text{RMS})} = \frac{I_{DC}}{2\sqrt{3}fC} \text{ volts for half wave}$$

• The r.m.s. ripple voltage is given by,

$$V_{r(\text{RMS})} = E_{DC} \times \text{Ripple factor}$$

Q.28 A 50 Hz transformer having 60 V rms on each side of the centre tap supplies a full wave rectifier circuit. The circuit load is 210 Ω with a shunt capacitor filter of 1000 μF . Find the ripple factor.

[JNTU : Part B, May-18, Marks 5]

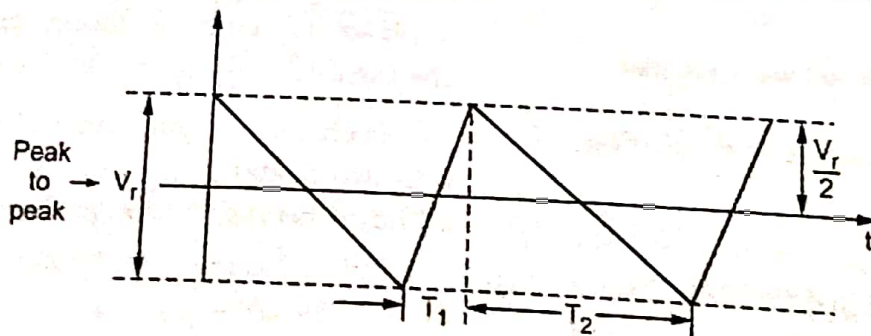

Fig. Q.27.1

Ans: $E_{s(rms)} = 60 \text{ V}$, $R_L = 210 \Omega$
 $C = 1000 \mu\text{F}$, $f = 50 \text{ Hz}$

$\gamma = \frac{1}{4\sqrt{3} f C R_L}$ = Ripple factor for F.W.R

$\gamma = \frac{1}{4\sqrt{3} \times 50 \times 1000 \times 10^{-6} \times 210} = 0.0137$

6.8 : Inductor Filter or Choke Filter

Q.29 Explain the operation of full wave rectifier with inductor filter with necessary diagrams.

Ans [JNTU : Part B, Dec.-14, 16, Marks 5]

Ans: The Fig. Q.29.1 shows the circuit diagram of full wave rectifier with inductor filter.

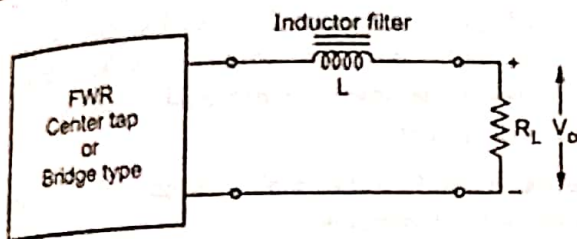

Fig. Q.29.1 Inductor filter with FWR

Operation

- An inductor has a property to oppose the change in current (alternating current) through it.
- When current through an inductor changes then an e.m.f. is induced in it. This is called back e.m.f. This e.m.f. opposes the cause producing it which is change in current.
- Thus when rectified output is given to the series inductor, it opposes the changing current which are ripples and it allows only d.c. to reach to the load.
- This makes the output smooth, removing ripple contents from it.
- For the operation of this filter, there must be current through the inductor all the time. Hence this filter is not used with half wave rectifier and only used with full wave rectifiers.
- Its ripple factor is given by,

$$\gamma = \frac{R_L}{3\sqrt{2} \omega L}$$

... $\omega = 2\pi f$

- It can be seen that, smaller the value of R_L , smaller is the ripple factor hence this filter is suitable for low load resistance i.e. high load current applications.
- For reducing ripple factor, L can be increased but practically high value of L makes it bulky and large in size. Also its d.c. resistance increases which reduces the output voltage.
- The Fig. Q.29.2 shows the waveforms with series inductor filter.

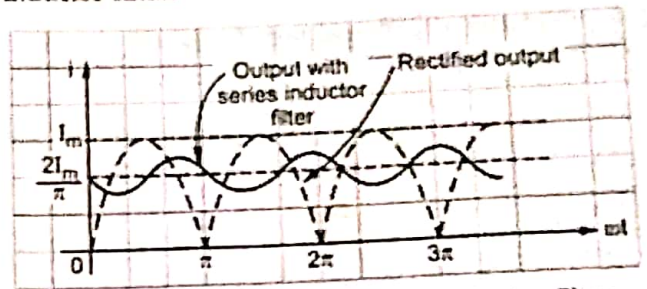

Fig. Q.29.2 Waveforms of series Inductor filter

- As inductors are bulky, costlier and more power consuming, series inductor filters are not used, now a days.

Q.30 Derive the expression for the ripple factor of a full wave rectifier using inductor filter.

Ans [JNTU : Part B, Aug.-17, Marks 5]

Ans. : For the full wave rectifier,

$$I_m = \frac{V_m}{R_L} \quad \dots \text{Neglecting } R_f$$

$$\therefore I_{DC} = \frac{2I_m}{\pi} = \frac{2V_m}{\pi R_L} \quad \dots (1)$$

while the load current i_L can be expressed in terms of harmonics as,

$$i_L = \frac{2I_m}{\pi} - \frac{4I_m}{3\pi} \cos 2\omega t$$

...Neglect higher order terms

with the second harmonic component, i_m can be expressed as,

$$I_m = \frac{V_m}{Z} = \frac{V_m}{\sqrt{R_L^2 + (2\omega L)^2}} \quad \dots (2)$$

Note that $Z = R + j 2 X_L = R + j 2\omega L$ as the ripple frequency is $2f$.

$$i_L = \frac{2I_m}{\pi} - \frac{4V_m}{3\pi\sqrt{R_L^2 + (2\omega L)^2}}$$

$$i_L = I_{DC} - \text{a.c. component present in } i_L \quad \dots(3)$$

$$I_{rms} = \frac{I_m}{\sqrt{2}} \text{ of a.c. component present in } i_L$$

$$= \frac{4V_m}{3\pi\sqrt{R_L^2 + (2\omega L)^2}} \times \frac{1}{\sqrt{2}} \quad (4)$$

$$\therefore \text{Ripple factor} = \frac{I_{rms}}{I_{DC}} \text{ and use (1) and (4)}$$

$$= \frac{\frac{4V_m}{3\sqrt{2}\pi\sqrt{R_L^2 + (2\omega L)^2}}}{\frac{2V_m}{\pi R_L}}$$

$$= \frac{2}{3\sqrt{2}} \times \frac{1}{\sqrt{1 + \frac{4\omega^2 L^2}{R_L^2}}}$$

As load current increases, R_L decreases hence the term $\frac{4\omega^2 L^2}{R_L^2} \gg 1$ and 1 can be neglected.

$$\therefore \text{Ripple factor} = \frac{2}{3\sqrt{2}} \times \frac{1}{\sqrt{\frac{4\omega^2 L^2}{R_L^2}}}$$

$$\text{Ripple factor} = \gamma = \frac{R_L}{3\sqrt{2} \omega L}$$

6.9 : L-section, Choke Input or LC Filter

Important Points to Remember

- The filter element looking from the rectifier side is an inductor so it is also called choke input filter.

Q31 Explain the operation of L-section filter with full wave rectifier.

[JNTU : Part B, Dec.-11,14, May-12, Marks 5]

Ans. : • The Fig. Q.31.1 shows L-section or LC filter with FWR.

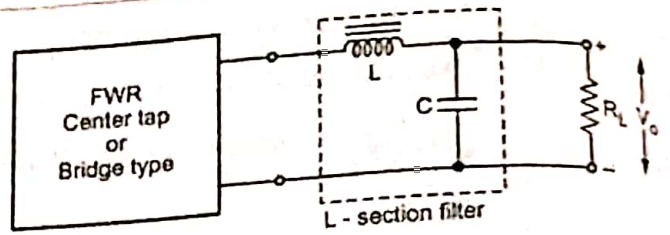

Fig. Q.31.1

Operation

- The rectifier output which is pulsating d.c. is applied to the choke L. The inductor offers very small resistance to d.c. and hence it allows d.c. component to pass to the load and it blocks a.c. component.
- Most of the ripples are blocked by an inductor but the remaining ripples are blocked by capacitor C. It offers small reactance to a.c. ripples and as connected in shunt with the load, it bypasses the remaining ripples.
- The capacitor C offers high reactance to d.c. hence it blocks d.c. component.
- Thus due to X_L and X_C reactances of L and C, almost pure d.c. component is available to the load. Due to the double filtering effect, the output of this filter is very smooth.
- Its ripple factor is given by,

$$\gamma = \frac{1}{6\sqrt{2} \omega^2 LC} \quad \dots \omega = 2\pi f$$

- It can be seen that the ripple factor is no dependent on the load resistance, which is its important advantage. It remains constant at all the loads.
- The Fig. Q.31.2 shows the waveforms of LC filter.

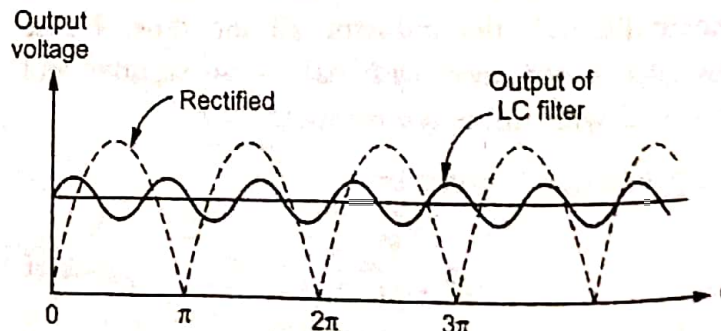

Fig. Q.31.2 Waveforms ac LC filter

This filter has good regulation and is suitable for all the loads, heavy as well as light loads.

Derive the expression for ripple factor for full wave rectifier with L-section filter.

EE (JNTU) : Part B, March-14, 17, Marks 5

The impedance Z_2 of the filter circuit for second harmonic component of input, i.e. at 2ω , will be,

$$Z_2 = (R_s) + (j 2\omega L) + \left[\frac{1}{\frac{1}{2\omega C} \parallel R} \right] \quad \dots (1)$$

but $\frac{1}{2\omega C} \ll R_s$ and $2\omega L \gg R_s$, as per assumptions.

Hence,

$$|Z_2| = 2\omega L \quad \dots (2)$$

Second harmonic component of the current in the filter circuit, will be

$$I_{2m} = \frac{\frac{4}{3\pi} E_{sm}}{Z_2} = \frac{\frac{4}{3\pi} E_{sm}}{2\omega L} \quad \dots (3)$$

The second harmonic voltage across the load is

$$E_{2m} = I_{2m} \times \left[\frac{1}{2\omega C} \parallel R \right] = I_{2m} \times \frac{1}{2\omega C} \quad \left(\frac{1}{2\omega C} \ll R \right) \quad \dots (4)$$

$$E_{2m} = I_{2m} \times \frac{1}{2\omega C} = \frac{\frac{4}{3\pi} E_{sm}}{2\omega L} \times \frac{1}{2\omega C} \quad \dots (5)$$

$$E_{2m} = \frac{4}{3\pi} \frac{E_{sm}}{4\omega^2 LC} = \frac{E_{sm}}{3\pi\omega^2 LC} \quad \dots (6)$$

$$E_{2rms} = \frac{E_{2m}}{\sqrt{2}} = \frac{E_{sm}}{3\sqrt{2}\pi\omega^2 LC} \quad \dots (7)$$

Hence the ripple factor is given by,

$$\text{Ripple factor} = \frac{E_{2rms}}{E_{DC}} = \frac{E_{sm}}{3\sqrt{2}\pi\omega^2 LC} \times \frac{1}{\frac{2}{\pi} \frac{E_{sm}}{1 + \frac{R_s}{R}}} \quad \dots (8)$$

$$= \frac{1}{6\omega^2 LC\sqrt{2}} \left(1 + \frac{R_s}{R} \right) \quad \text{but } R_s \ll R \quad \dots (9)$$

$$\text{Ripple factor} = \frac{1}{6\sqrt{2}\omega^2 LC} \quad \dots (9)$$

EE (JNTU) : Part A, May-04, Aug-08, Marks 1

Q1) Explain the necessity of bleeder resistance in LC filter.

Necessity of Bleeder Resistance

The basic requirement of an inductor is that the current through it must be continuous and not interrupted.

- If current through L is interrupted, it develops large back e.m.f. which may exceed PIV rating of the diodes and voltage rating of capacitor C. This may damage diodes and capacitor.
- To avoid this, inductor L must carry minimum current all the time continuously without any interruption. For this purpose a resistance R_B is connected across the output terminals, which is called bleeder resistance.
- The bleeder resistance is shown in the Fig. Q.33.1.

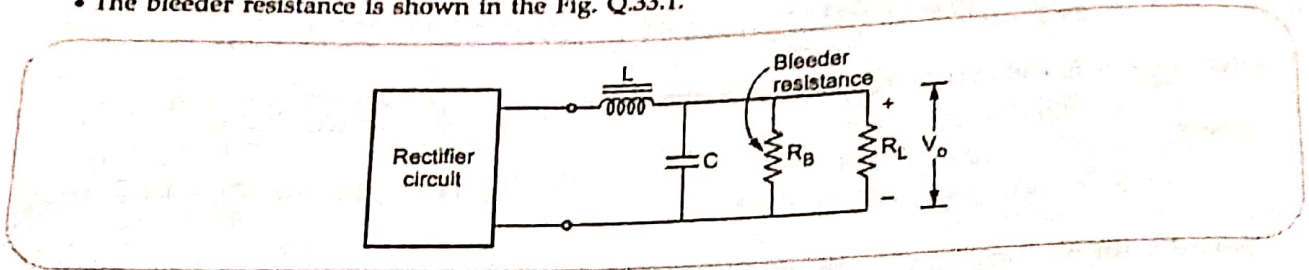

Fig. Q.33.1 LC filter with bleeder resistance

[JNTU : Part B, Aug.-17, 18, Marks 5]

Q.34 Compare capacitor input filter and LC filter.

Ans. : Comparison between capacitor input and LC filter

Sr. No.	Capacitor Input Filter	LC Filter
1.	The first element of the filter as looked from rectifier side is capacitor.	The first element of the filter as looked from rectifier side is inductor.
2.	The surge current is possible which is limited by using surge limiting resistor.	The surge current through diodes is absent.
3.	Possibility of large back e.m.f. is absent hence bleeder resistance is not required.	Possibility of large back e.m.f. which is harmful to diodes and capacitor. To avoid this, bleeder resistance is used.
4.	The ripple voltage is a function of load current i.e. load resistance.	The ripple voltage is not dependent on the load.
5.	The regulation is poor.	The regulation is better.
6.	Not suitable for variable loads.	Suitable for variable loads.
7.	The d.c. output voltage is higher as the capacitor always charges to peak value.	The d.c. output voltage is low compared to capacitor input filter.
8.	Normally used for single phase, high voltage, fixed load applications.	Used in polyphase rectifier systems employing mercury arc rectifiers.
9.	The ripple factor is, $\gamma = \frac{1}{4\sqrt{3} f C R_L} \dots \text{for full wave}$	The ripple factor is, $\gamma = \frac{1}{6\sqrt{2} \omega^2 L C} \dots \text{for full wave}$

6.10 : PI(π) Section Filter or CLC Filter

Describe the operation of full wave rectifier with π section filter.
 The Fig. Q.35.1 shows π filter with FWR.

[JNTU : Part B, May-18, Marks 5]

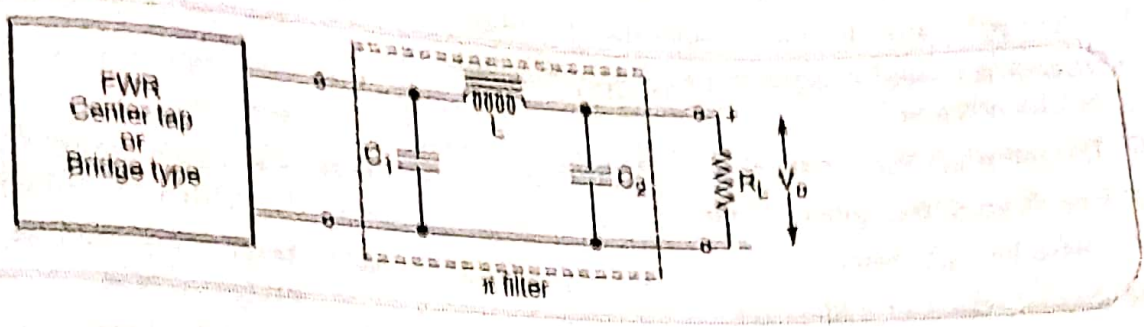

Fig. Q.35.1

Operation

- The rectifier output is given to the capacitor C_1 which is connected in parallel with the output of the rectifier. This capacitor offers very low reactance to the a.c. component but blocks d.c. component. Hence capacitor C_1 bypasses most of the a.c. component.
- The d.c. component then reaches to the choke L. The choke L offers very high reactance to a.c. component and very low reactance (almost zero) to d.c. So it blocks a.c. component and does not allow it to reach to load while it allows d.c. component to pass through it.
- The capacitor C_2 now allows to pass remaining a.c. component by offering very low reactance to a.c. ripples. Thus almost pure d.c. component reaches to the load.
- The ripple factor for this filter is,

$$\gamma = \frac{\sqrt{2}}{8\omega^3 LC_1 C_2 R_L}$$

... $\omega = 2\pi f$

- It can be seen that the ripple factor increases as R_L decreases i.e. load current increases. Thus this filter is not suitable for high load currents hence it is preferred for light loads.
- The Fig. Q.35.2 shows the waveforms of π (PI) filter.
- The output of this filter is very smooth but it is suitable only for light loads.

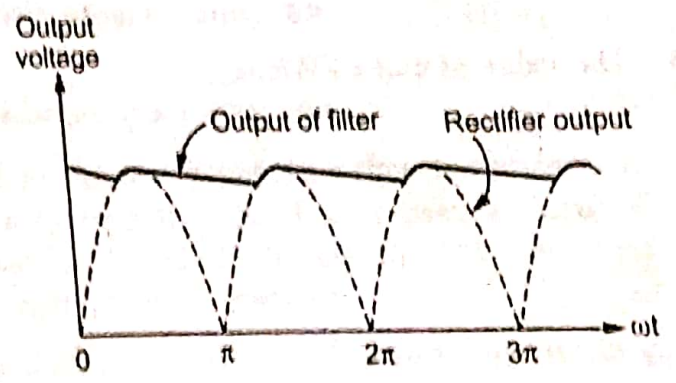

Fig. Q.35.2 Waveforms of π filter

Q.36 State the advantages and disadvantages of pi section filter. [JNTU : Part A, Marks 3]

Ans. : Advantages and Disadvantages

- The various advantages of π filter are,
 - 1) The ripple factor is much smaller than LC filter.
 - 2) Higher d.c. output voltage at high load currents can be obtained.
 - 3) The output is very smooth.
 - 4) Easy from design point of view.
 - 5) Useful for light loads.
- The disadvantages of π filter are,
 - 1) It is bulky due to more number of filter components.
 - 2) Higher PIV rating for the diodes is required.
 - 3) Regulation is poor.
 - 4) The large value of input capacitor C_1 is necessary.
 - 5) The inductor of high current rating is required hence costly.